

Complete fire systems for the protection of life and property



EATON

Powering Business Worldwide

Energizing a world that demands more.

Discover today's Eaton.

Powering business worldwide

As a global power management company, we help customers worldwide manage the power needed for buildings, aircraft, trucks, cars, machinery and businesses.

Eaton's innovative technologies help customers manage electrical, hydraulic and mechanical power more reliably, efficiently, safely and sustainably.

The Eaton logo consists of the word "EATON" in a bold, blue, sans-serif font. The letter "O" is replaced by a solid blue circle.

Powering Business Worldwide



We deliver:

- **Electrical solutions** that use less energy, improve power reliability and make the places we live and work safer and more comfortable
- **Hydraulic and electrical solutions** that enable machines to deliver more productivity without wasting power
- **Aerospace solutions** that make aircraft lighter, safer and less costly to operate, and help airports operate more efficiently
- **Vehicle drivetrain and powertrain solutions** that deliver more power to cars, trucks and buses, while reducing fuel consumption and emissions

We provide integrated solutions that help make energy, in all its forms, more practical and accessible.

With 2015 sales of \$20.9 billion, Eaton has approximately 100,000 employees around the world and sells products in more than 175 countries.



Eaton's electrical business

Eaton is a global leader with expertise in:

- Power distribution and circuit protection
- Backup power protection
- Solutions for harsh and hazardous environments
- Lighting and security
- Structural solutions and wiring devices
- Control and automation
- Engineering services

Eaton is positioned through its global solutions to answer today's most critical electrical power management challenges. With 100 years of electrical experience behind us, we're energized by the challenge of powering up a world that demands twice as much energy as today. We're anticipating needs, engineering products and creating solutions to energize our markets today and in the future.

We are dedicated to ensuring that reliable, efficient and safe power is available when it's needed most.

Eaton.com

Leadenhall Building
London, UK



Excellence and innovation in fire safety solutions.

When it comes to protecting life and property there's no room to compromise. You need a partner that can support you with tried and tested products, global capabilities and local delivery.

Eaton is a leading manufacturer and global supplier of high quality fire systems. With our ability to provide complete systems, not just components, you can be confident in the knowledge that all of our products have been specifically designed and tested to ensure that they are all fully compatible to form a reliable and compliant fire detection and alarm system.

Our large multi-disciplined research and development team is responsible for the integration of the latest technology into the full range of fire products, ensuring that our products are designed to the latest fire industry standards and manufactured to the highest levels of quality. The many innovative, new and improved products featured in this catalogue demonstrate our commitment to staying at the leading edge of technological development for fire detection and alarm equipment.

Our core values and aims are:

- Investment in people
- To partner with our customers to develop open, long term relationships
- To have an unpretentious, straightforward and honest approach to business
- The continued investment in research and development
- Investment in manufacturing facilities to ensure they remain world class
- To produce products that are in full compliance with standards
- To operate in an environmentally friendly way - in the products we design and the facilities in which we make them
- To have high ethical standards

Our solutions and services are recognised by a wide range of accreditation bodies, so you can count on products that comply with national and industry standards, while receiving full support, from initial system design to monitoring and service.



Introduction

Distinctive capabilities



Ankara Esenboğa International Airport
Ankara, Turkey



St Pancras Station
London, UK



Doncaster Cultural and Civic Quarter
Doncaster, UK

Manufacturing fire solutions is just one small element of what we do.

Services

We believe that ownership of fire detection systems extends beyond the initial purchase of the products themselves. We therefore offer customers a wide range of services to ensure that their installations not only meet basic operational and safety requirements on day one, but will continue to do so throughout their lifetime.

From training and support on how to select products for a specific application through to the provision of routine on-site testing and maintenance. You can be sure that Eaton is ready to support you, whatever your needs.

Major projects

Design and installation of a fire detection system can often be a complex process, with each project often bringing its own challenges in making sure the system is compliant, reliable and easy to operate. Our team of engineers will partner with your project management team using our expertise to meet the specific requirements of your project.

Eaton has a great deal of experience handling major projects across the globe. We can help not just with the product and technical support but also by providing guidance and advice to specifiers and project management teams on topics such as standards and regulations.

We are BAFE SP203 certified for design, commissioning and maintenance of fire detection systems, giving our customers the peace of mind they need that our systems conform with all necessary safety requirements.

Technical support

Our dedicated technical support team are able to offer customers around the world advice and guidance on a wide variety of technical matters via telephone or email. In the vast majority of cases, a process of systematic questioning enables the team to diagnose the challenge and advise the customer on the appropriate solution.

Sometimes more detailed troubleshooting and analysis methods may be used to determine the actual requirements and the best way of resolving it. If necessary, the technical support team will also call on the knowledge and expertise of Eaton's product management, R&D and design departments to help resolve the customer's issue.

In addition, the technical support team can provide customers with assistance on product information, installation and operating instructions, and the legislative requirements of your fire detection systems.



Mariner's Quay Apartment Complex
Newport

Contents

1. Introduction

An introduction to fire systems	10
Conventional and two-wire systems	12
Addressable systems	13
Emergency voice communication systems	14
UL listed fire systems	15
Voice alarm systems	15

2. Intelligent addressable systems

Fire panels and repeater panels	18
Addressable devices	24

3. UL intelligent addressable systems

Fire panels and repeater panels	44
UL listed devices	46

4. Two-wire and conventional systems

Two-wire control panel	58
Two-wire devices	60
Fire panels and repeater panels	62
Conventional devices	68

5. Emergency voice communications

VoCALL control panels	84
VoCALL devices	88
Emergency assist alarm	90

6. Voice alarm systems

Control panels and amplification Speakers	94
	96

7. Appendix

Part code lookup	
Contact details	98
	109

An introduction to fire systems

Eaton manufacture and supply a range of different types of fire systems, meaning we can provide a high quality fire solution whatever your need is. There are a vast array of fire detection systems and devices on the market today, ranging from the relatively simple to the most technically sophisticated. Modern automatic fire detection systems are available in two types, conventional and addressable - which, broadly speaking, tend to be used in smaller and larger installations respectively. For more detail you can read our fire systems guide over the next few pages.

The basics of fire detection

A control panel is the hub of the detection system. All the devices which are part of the fire detection system are connected to this central panel which processes the signals received from the input devices and gives out signals to the output devices. Input devices such as detectors measure signals of combustion and communicate with panels, which in turn trigger output devices such as an audible or visual alarm device. Fire alarm panels can be further sub segmented into addressable or conventional panels.

There are various types of fire detection systems each suited to different applications or building types. A fire detection system can vary significantly in both complexity and price, from a single panel with a detector and sounder in a small commercial property to a complex intelligent addressable system in a multi-occupancy building.

A fire detection system can comprise of detection devices, notification devices and manual callpoints. The size of the building determines the number of detectors that would be required. The system works via the control panel receiving signals from the detection devices and then sending transmitting signals to the notification devices.



Introduction

Conventional fire systems

Conventional systems (p64-83)

The philosophy of a conventional system revolves around dividing the building into a number of areas called zones. The detectors and call points within each zone are then wired on a dedicated separate circuit.

In the event of a detector or call point being triggered, the panel is able to identify which circuit contains the triggered device and thereby indicate which zone the fire alarm has come from. The indicated zone can then be manually searched to locate the triggered device.

With this type of functionality a conventional system is best used in smaller builds where it wouldn't be difficult to locate the triggered device in a given zone.

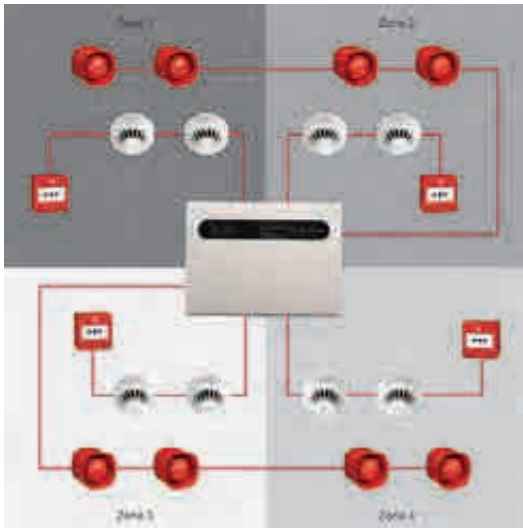

Typical conventional system architecture

Two-wire systems (p58-63)

Two-Wire systems are based on standard conventional system technology, but it also incorporates additional functionality to enable the callpoints, detectors and sounders for each separate zone to be wired on a single common circuit.

By combining both the detection and the alarm annunciation wiring into a single circuit, considerable savings in installation time and cabling can be achieved.

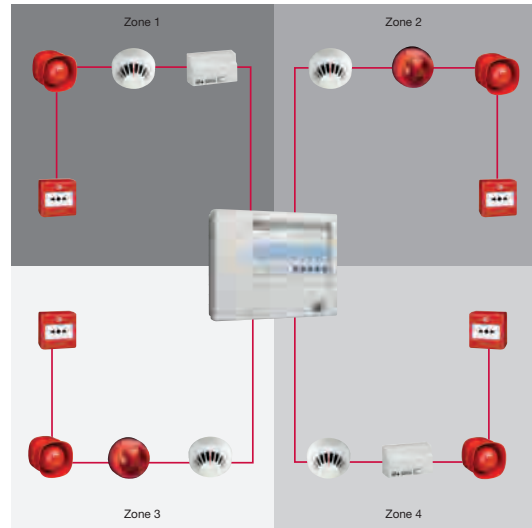

Typical two-wire system architecture

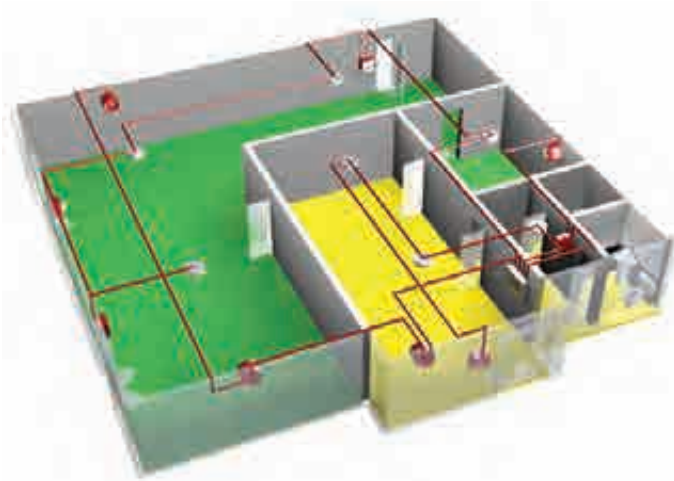

Example conventional system layout



Example two-wire system layout



Addressable systems (p17-41)

Intelligent addressable systems overcome the limitations of conventional systems as each fire detecting sensor or call point is electronically coded with a unique identification or 'address' which is programmed into the device during installation.

By using each devices' unique address, the control panel is able to conduct two way communication with any of the addressable devices connected to the system.

Under normal conditions the control panel continuously interrogates each device in sequence and analyses the reply to determine the status of each sensor or call point. The panel checks whether each device is functioning correctly and also the amount of smoke or heat that the device is currently sensing.

With the functionality of being able to pinpoint exactly which device is being triggered in an alarm or for a fault, addressable systems are perfect for mid to large size builds with multiple rooms and floors.

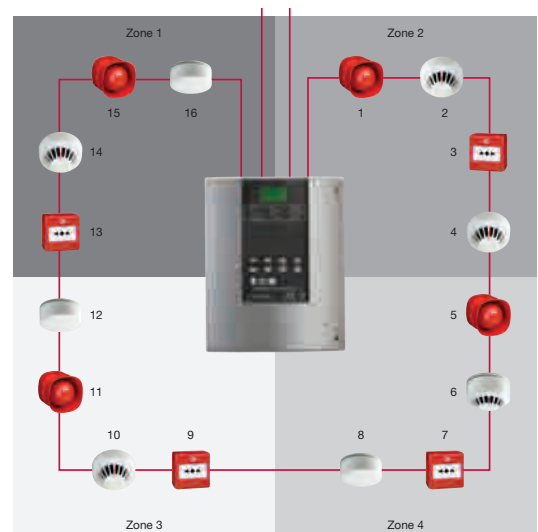

Typical addressable system architecture

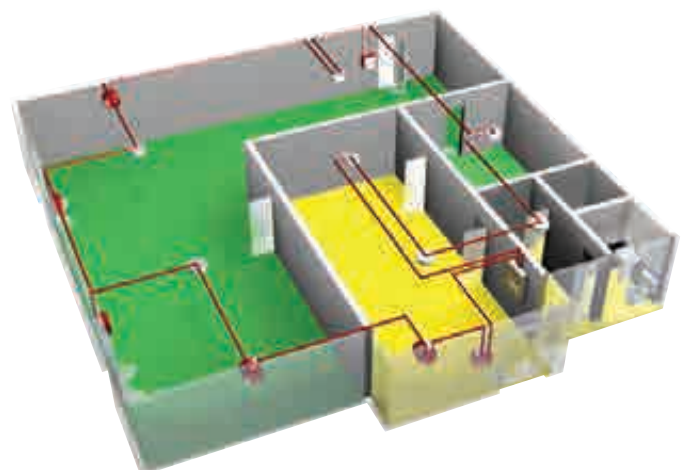

Example addressable system layout

Introduction

Emergency voice communication systems



Emergency voice communication systems (EVCS) (p85-93)

What is disabled refuge?

A disabled refuge is a relatively safe area within a building or exit staircase for mobility impaired occupants, allowing building management and emergency services to safely assist these people from the building.

Mobility impairment is defined as not being able to walk 200m continuously without aid, and includes arthritis sufferers, people with leg and back injuries and women over 6 months term pregnancy.

What is a fire telephone?

Fire telephones are hardwired full duplex communications systems with monitoring and battery backup and are required in buildings over 4 storeys in many countries in the world (in the UK this is governed by BS9999, 2008). These are provided as a backup to traditional fireman's radio systems, which can fail to operate in many high rise environments due to the large amount of steel in the building, and the "corona" effect of fire on radio broadcasts.

Fire telephones are also required in fire fighting lift lobbies when these lifts are provided within a building. Fire telephones can also be used for fire

wardens to call the control point during fire drills and primary evacuation phases before the fire services arrive and assume control.

What is a disabled refuge EVC system?

An EVC System (Emergency Voice Communication System) is a fixed, monitored and maintained, bi-directional, full duplex voice communication system. These systems are designed to assist the orderly evacuation of disabled or mobility impaired people and enhance fire fighters' communication during emergencies.

A disabled refuge system is not just for use during a fire and must be available at all times. Building Regulations insist all new non-domestic buildings with more than one storey provide 'refuge' areas – relatively safe places where people who cannot easily use fire escapes and evacuation lifts, can call for assistance and wait until help arrives. Simple, effective two-way communication (refuge system) in these areas is essential, firstly to assist rescue teams in determining where assistance is required and secondly to reassure people help is on the way.

UL listed fire systems (p44-56)

Underwriters Laboratories Inc. (UL) is an independent product safety certification organisation, established in 1894, to develop standards and test procedures for products, materials, components, assemblies, tools and equipment. Chiefly dealing with product safety it also evaluates and certifies the efficiency of a company's business processes through its magnificent system registration programs.

Since the launch of our UL Listed fire product range, several prestigious projects worldwide have been supplied including Hyatt Resort and Spa, Shangri-la at the Fort and Times Square projects

in South East Asia and several major projects in the Middle East including the prestigious Riyadh Financial District in the Kingdom of Saudi Arabia.

The Eaton UL range is designed to provide a solution for all sizes of project, from the simple small stand alone system to the large multi panel networked system with PAVA and BMS integration.

SIGNALING

LISTED
4AC5FIRE ALARM
EQUIPMENT

Public address/voice alarm systems (p95-99)

Under BS5839 Pt.8 2013, Voice Alarm (VA) systems are recommended for all public buildings and multi-storey buildings over four floors. VA systems are the quickest way to evacuate the public and staff from a building.

Following fire detection, automated messages control the flow of people in stair wells and corridors allowing an orderly evacuation without panic. These messages are supplemented by spoken messages from the fire service or management suite confirming the validity and need to leave the building. This positive confirmation speeds evacuation and avoids the "false alarm" mentality reducing the risk of death from fire.





Contents

Intelligent addressable systems

Panels

CF2000 addressable panel 18



CF1100VDS addressable panel 20



CF3000 addressable panel 22



Devices

Sensors 24



Bases 26



Callpoints 28



Wall sounders and VADs 29



Beam detector 31



Duct probe 31



Interfaces 32



Micro interfaces 35



Networking interfaces 36



Ancillaries 38



Software 40



Test equipment 41



CF2000GCPD

Intelligent addressable control panel



“The CF2000GCPD serves as the optimum solution for buildings requiring smaller addressable systems.”

The Eaton CF2000GCPD is an entry level intelligent addressable control panel which can be configured for either 1 or 2 loop operation, and is certified to EN54 parts 2 & 4.

The panel has a graphic display, providing a simple menu driven end user interface. With the CF2000GCPD's ability to support Eaton cause and effect programming and a range of user controllable functions it makes the panel suitable for a varied range of projects from small warehouses to small/medium office developments as well as many small industrial applications.

As with all Eaton intelligent addressable panels, the CF2000GCPD uses "spur tolerant" soft addressing to minimise installation time and remove the potential for errors often associated with many forms of manual addressing.

Benefits

- Configurable as a 1 or 2 loop panel
- Up to 200 addresses per loop (up to 60 sounders/beacons and up to 20 I/Os, subject to loop loading calculations)
- Soft addressing
- Menu-driven graphic screen
- Multi-language selection capability
- Integral battery and power supply
- 2x7Ah batteries included
- Easy to operate end user controls
- Full system integrity with Eaton developed protocol
- Core range of compatible devices
- 4 sounder circuits
- Monitored for open and short circuit (max 3.0A combined)

Dimensions

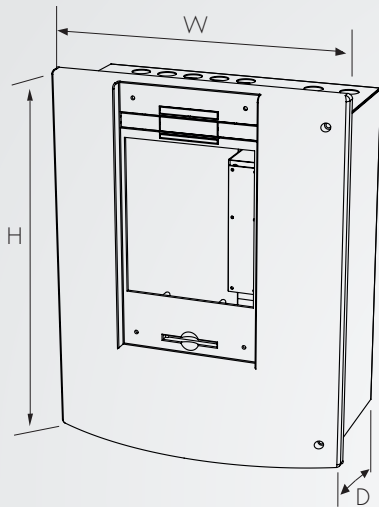

H (mm)	W (mm)	D (mm)
400	320	170

Catalogue numbers

Description	Code
Intelligent addressable 2 loop control panel	CF2000GCPD
Standard repeater panel	CF3000PRG
Fire alarm system log book	MFALOG

Compatible repeater panels

The CF2000GCPD has a standard repeater panel available. Ideal for larger sites, the repeater allows you to display the system information from multiple locations.



24V dc output

Features	CF3000PRG
Active or passive option	✓
Integral battery and power supply	✓
Supervisor and engineer modes through code access	✓



CF1100VDS

Intelligent addressable control panel



“The simplicity of operation, powerful cause and effect programming capability and competitive pricing make the system suitable for a wide range of small to medium sized projects.”

The CF1100VDS is a high specification addressable panel for medium sized builds that is equipped with a versatile touch screen user interface. It is available as a 1 (CF1100VDS) or 2 (CF1200VDS) loop panel.

The powerful cause and effect programming capability and competitive pricing make the system suitable for a wide range of small to medium sized projects. The panels can operate as standalone or as part of a network with our other addressable panels (additional network card required).

Benefits

- Soft addressing
- Large versatile touch screen user interface
- Multi-language selection capability
- Integral battery and power supply
- 2x7Ah batteries included
- Flexible distributed network capability
- Full range of compatible devices
- Flexible and easy to design, system cause and effect using site installer software
- Compatible with our addressable repeaters (see p21)

	CF1100VDS	CF1200VDS*
No. of loops	1*	2*
Addresses per loop	200**	200**
No. of conventional sounder circuits	2***	2***

* No zonal LEDs

** Up to 60 sounders/beacons and up to 20 I/Os

*** Monitored for open and short circuit (max 1.5A combined)

Dimensions

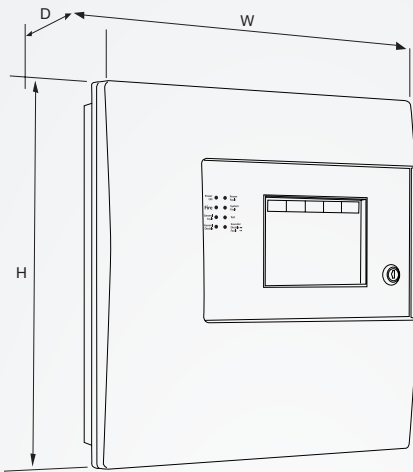

	H (mm)	W (mm)	D1 (mm)
Panel	375	357	95
Cutout	345	325	50



CF1100VDS pictured with a range of compatible devices

Catalogue numbers

Description	Code
1 loop control panel	CF1100VDS
2 loop control panel	CF1200VDS
Add to end of product code if network card required	NC
Add to end of product code if dual redundancy network card required	NCDR
Network kit (for retro fit)	DF61NETKIT
Passive repeater panel	CF3000PRG
Touch-screen repeater panel	CTPR3000
Fire routing equipment PCB	ZPCB2187FRE
Fire alarm system log book	MFALOG



CF3000

Intelligent addressable control panel



“The large capacity, ability to support complex cause and effect programming and wide range of user controllable functions make the system suitable for a diverse range of projects”

The CF3000 series are high specification intelligent addressable control panels, which are fully certified to EN54 parts 2 and 4.

The panel comes with options for an integral printer for system posterity and an extended battery. Each panel is networkable with up to 126 other Eaton addressable control panels, only requiring the addition of one of our network cards for this functionality.

	CF30002G	CF30004G
No. of Loops	2	4
Addresses per Loop	200*	200*
No. of Conventional Sounder Circuits	4**	4**

* Up to 60 sounders/beacons and up to 20 I/Os

** Monitored for open and short circuit (max 1.5A combined)

Benefits

- Soft addressing
- Large versatile touch screen user interface
- Multi-language selection capability
- Integral printer (optional)
- Integral battery and power supply
- 2x 12Ah batteries included
- Extended battery option allows for 72 hours standby (subject to loop loading calculations)
- Flexible distributed network capability
- Full range of compatible devices
- Easy to design system cause and effect using site installer software
- Additional functionality through FRE & FPE (Fire Routing Equipment & Fire Protection Equipment) which are both monitored outputs

Class change functionality

Our CF3000 panel has a variety of easy to use additional software options on top of the standard class change facility; this provides benefits for a number of regions.

Class change input on the CF3000 can be used for functions such as Australian Fire Brigade, HMO operation, Swedish mode, Australian tone sounders for class change and different tones.



Compatible repeater panels

The CF3000 has both a passive and a touchscreen repeater panel available. Ideal for larger sites, the repeater allows you to display the system information at multiple locations.



Features	CF3000PRG	CTPR3000
Active or passive option	✓	✓
No programming required	x*	✓
Programmable input	x	✓
Integral battery and power supply	✓	✓
Supervisor and engineer modes through code access	✓	✓
Fire and fault volt free programmable relays	x	✓
Adjustable volume from panel	x	✓

*Programming not required on network version.

Dimensions

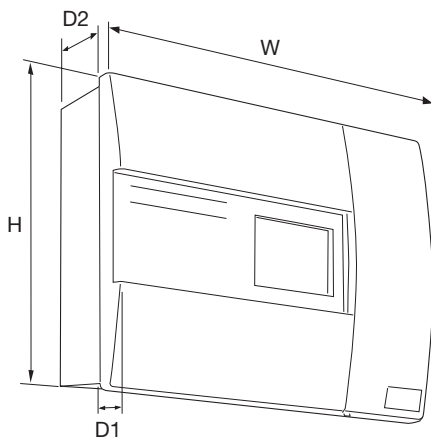

	H (mm)	W (mm)	D1 (mm)	D2 (mm)
Standard	397	497	55	125
EB*	397	497	55	225

*Extended battery version

Catalogue numbers

Description	Code
2 loop control panel	CF30002G
4 loop control panel	CF30004G
2 loop control panel, integral printer	CF30002GP
4 loop control panel, integral printer	CF30004GP
2 loop control panel, extended battery	CF30002GEB
4 loop control panel, extended battery	CF30004GEB
2 loop control panel, integral printer, extended battery	CF30002GPGB
4 loop control panel, integral printer, extended battery	CF30004GPGB
Add to end of product code if network card required	NC
Add to end of product code if loop card required	LC
Network kit (for retro fit)	DF6000NETKIT
Printer kit (for retro fit)	CF3000PKIT
Hinged protective cover kit	CF3000COV
Passive repeater panel	CF3000PRG
Touch-screen repeater panel	CTPR3000
Fire alarm system log book	MFALOG

Sensors

Our addressable range has multiple options for intelligent addressable sensors. All sensors are designed for optimum functionality in mid-large sized builds. They are all soft addressed and have integral short circuit isolators. We also offer a loop connected remote indicator, designed to offer discreet remote indication and an ability to monitor multiple sensors. This helps to minimise wiring requirements.

Optical smoke sensor CAP320



Typical applications:

Suitable for most applications.

Fastest response to slow burning or smouldering fires which give rise to large visible smoke particles.

Photo-thermal sensor CAPT340*



Typical applications:

Responds quickly to fast clean burning fires.

Maintains the advantage of optical sensors when detecting smouldering fires.

Heat sensor CAH330



Typical applications:

Environments where the ambient conditions might cause false alarms with smoke detectors.

Examples include areas with high levels of dust or fumes.

The CAH330 can operate in 3 modes: rate of rise, fixed heat 77°C and fixed heat 90°C.

These modes are set by the panel.

*The CAPT340 has day/night modes available, programmeable from the site installer software. The day mode uses the heat aspect of the sensor for areas which may have smoky environments during, for example working hours. The night mode uses a combination of A2S and smoke detection. If not programmed, the sensor defaults to dual mode.

Dimensions

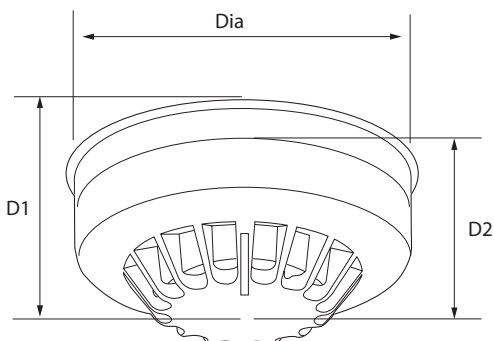

Description	Diameter (mm) (incl base)	Depth (mm) (excl base)	Depth (mm) (incl base)
Optical	104	33	45
Photo-thermal	104	43	55
Heat	104	43	55

Performance

Feature	CAP320	CAPT340	CAH330	CAH330	CAH330
Mode	Optical	Photo-thermal	Rate of rise	Fixed heat 77°C	Fixed heat 90°C
Area coverage*	100m ²	100m ²	50m ²	50m ²	50m ²
Heat class	N/A	A2S	A2R	BS	CS
Alarm temperature	N/A	60 °C	60 °C	77 °C	92 °C

*(subject to local standards)

Catalogue numbers

Description	Code
Optical smoke sensor - CAP320	400002FIRE-0002X
Photo-thermal sensor - CAPT340	400004FIRE-0004X
Multi-mode heat sensor - CAH330	400003FIRE-0003X

Indicators

Our indicators are designed as additional indication devices when sensors have been triggered. These products are designed to be used as indicators only, and not visual alarm devices (see p26 and 29 for EN54-23 certified VADs).

Addressable remote indicator MRIAD



Typical applications:

Monitoring multiple sensors within a specific area.
Must be configured through site installer. The remote indicator can be programmed as a sounder.

Standard remote indicator CIR301



Typical applications:

The CIR301 can only be connected to one sensor and is powered by this sensor.
There is a weather resistant version also available. (Not IP65).

Staff warning device CAB382



Typical applications:

As this product does not meet EN54-23 requirements as a beacon we recommend it as an internal warning device in offices, schools or manned reception areas.



Remote indicator lens detail

Dimensions

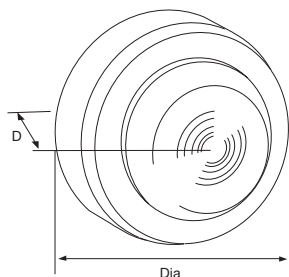

Staff warning device

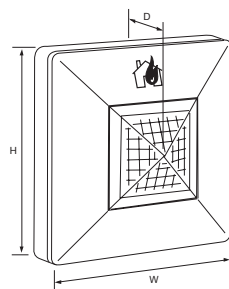

Remote indicators

Description	Diameter (mm)	Depth (mm)
Staff warning device	101	33

Description	Height (mm)	Width (mm)	Depth (mm)
Remote indicators	87	87	30

Catalogue numbers

Description	Code
Loop connected remote indicator	MRIAD
Standard remote indicator	CIR301
Weather resistant standard remote indicator	CIR301WP
CAB382 Staff warning device	666028FULL0066

Bases

We stock a variety of bases, providing a wide functionality for different situations. The standard base (CAB300) provides a foundation for our addressable sensors. The range of bases also includes capability for additional sounder and sounder beacon operation. Both our sounder base (CAS380) and VAD sounder beacon base (CASBB394) can be used as standalone devices when fitted with our cover plate (CASC).

Standard base CAB300



Typical applications:

General use product, recommended for use in all environments

Sounder base CAS380



Typical applications:

Areas of limited extent, where lower output volume is required
Areas with limited cable space
Concrete ceilings, to save cabling

Sounder beacon base CASBB394 (CASBB384)



Typical applications:

The CASBB394 is an EN54-23 certified Visual Alarm Device (VAD) sounder beacon base. It is compatible with the Eaton range of intelligent addressable sensors and can also be used as a dedicated discreet standalone device.

(The CASBB384 sounder beacon base is also available for indication purposes, where EN 54-23 is not a requirement.)

Sounder base with cover CAS380 + CASC



Typical applications:

Optional cover plate can be used to enable the sounder to operate as a dedicated discreet standalone device



VAD sounder beacon base shown with optical sensor

Features

	CAB300	CAS380	CASBB384	CASBB394
First fix base	✓	✓	✓	✓
Loop integrity switch	✓	✓	✓	✓
Multiple cable entry points	✓	✗	✗	✗
Selectable tones	✗	✓	✓	✓

Performance

	CAS380	CASBB394
Sound output		
Low volume	84dB at < 4mA	77dB at < 6.6mA
Medium volume	92dB at < 8mA	89dB at < 8mA
High volume	95dB at < 12mA	90dB at < 9mA
Flash rate		
	n/a	0.5 Hz flash*

*Polar dispersion information available on datasheet

Dimensions

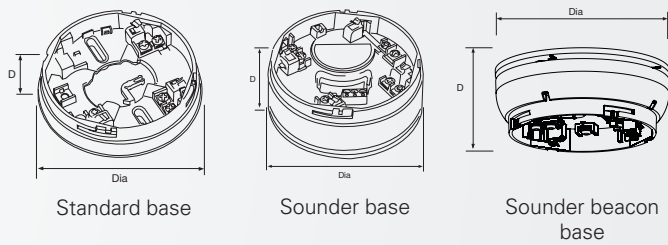

Description	Diameter (mm)	Depth (mm)
Standard base	104	22
Sounder base	102	40
Sounder beacon base	115	44

Catalogue numbers

Description	Code
Standard base	CAB300
Sounder base	CAS380
VAD sounder beacon base	CASBB394
Sounder beacon base	CASBB384
Cover plate (pack of 5)	CASC
Bell tone sounder base	CAS380B
Australian sounder base*	CAS380AU*
Addressable relay base	MAB800R
Base shroud	BAR3000

* Only for Australian market



Intelligent addressable systems

Devices - callpoints

Callpoints

Two versions of the intelligent addressable callpoint are available, the surface/flush mounted CBG370S or the weatherproof CBG370WP. Both have an integral short circuit isolator and are very simple to install. The callpoints are packaged with 2 frangible glass elements and test key, with a comprehensive range of further accessories available.

Surface/flush mounted callpoint CBG370S



Typical applications:

General use product, suitable for use in most indoor applications.

Weatherproof callpoint CBG370WP



Typical applications:

Builds requiring a callpoint in harsh conditions. For example, outside or in a wash down area.

Dimensions

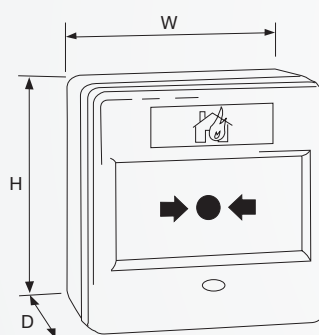

Description	H (mm)	W (mm)	D (mm)
Surface mounted	87	87	36
Flush mounted	87	87	57
Weatherproof	87	87	59

Features

	CBG370S	CBG370WP
Fast fit clip	✓	✓
High Visibility LED	✓	✓
Heavy duty terminals	✓	✓
Ingress protection	IP24D	IP65

Catalogue numbers

Description	Code
Surface/flush callpoint	CBG370S
Weatherproof callpoint	CBG370WP
CXPC Protective hinged cover (pack of 10)	4990001FUL-0022
Spacer plates (pack of 10)	MBGSP
MBGBEZ Recessing bezels (pack of 10)	4990005FUL-0194
MBGREKIT Resettable element kit (pack of 10)	4990010FUL-0045
UBSG Spare break glasses (pack of 5)	516200FULL-5017
MFBGKEY3 Callpoint keys (pack of 10)	4990009FUL-0040

Further accessories:



Callpoint shown with protective hinged cover

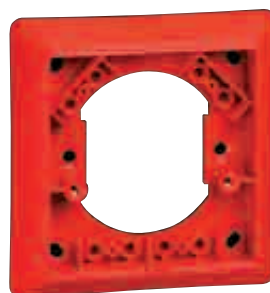

Callpoint recessing bezel

Wall sounders and VADs

There are also two versions of our intelligent addressable wall sounder, the internal (CAS381) and the weatherproof (CAS381WP). Their highly efficient design offers excellent sound output levels despite the low current consumption. They both contain an integral short circuit isolator and have multiple tones and volume levels which can be controlled from the panel globally, or individually via site installer.

We also offer a new open class Visual Alarm Device (CASB393), combining the high output sound of the wall sounders with a stronger LED to meet the EN54-23 VADs requirements. The open class functionality allows the VADs to be installed in open areas such as warehouses or airport terminals.

Wall sounder CAS381/CAS381WP



Typical applications:

Both an indoor and weatherproof variant of the wall sounder are available, allowing for consistent performance for any application where a wall sounder is required.

VAD wall sounder beacon CASB393/CASB393WP CASB383*/CASB383WP*



Typical applications:

The CASB393 is an addressable open class VAD suitable for all markets where EN54-23 VADs are now a requirement. **White flash only.**

(The CASB383 wall sounder beacon is also available for indication purposes, where EN 54-23 is not a requirement. **Red flash only.**)

Dimensions

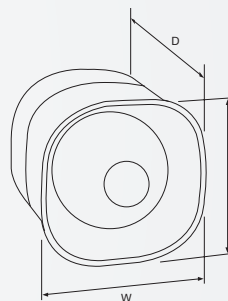

Internal wall sounder /
sounder beacon

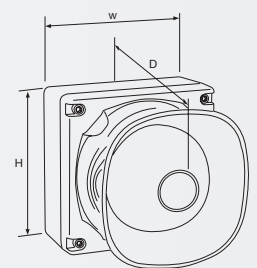

Weatherproof wall sounder/
sounder beacon

Description	H (mm)	W (mm)	D (mm)
Wall sounder	105	105	95
WP wall sounder	108	108	103
VAD sounder beacon	108	108	96
WP VAD sounder beacon	110	110	105

Tones

	CAS381/ CAS381WP	CASB393/ CASB393WP	CAS381B/ CAS381WPB	CAS381AU/ CAS381WPAU	CASB394B
Continuous	✓	✓	✓	✓	✓
Two tone @ 1Hz cycle	✓	✓	✓	✗	✓
Slow whoop 500-1200Hz in 3.5 seconds / 0.5secs gap	✓	✓	✗	✗	✗
Pulsed 1Hz (Virtual Tone)	✓	✓	✓	✓	✓
Pulsed sweep ISO8201 3x500ms 800-970Hz 1 ½ Sec Gap	✗	✗	✗	✓	✗
Bell tone	✗	✗	✓	✓	✓

Sound output

	CAS381/CAS381WP	CASB393/CASB393WP
Low volume	87dB at < 2mA	87dB at < 8.6mA
Medium volume	93dB at < 3mA	93dB at < 10mA
High volume	100dB at < 6mA	100dB at < 11mA
Flash rate	n/a	0.5Hz Flash

Catalogue numbers

Description	Code
Internal wall sounder	CAS381
Weatherproof wall sounder	CAS381WP
Vad wall sounder beacon	CASB393
Weatherproof VAD wall sounder beacon	CASB393WP
Internal wall sounder bell tone	CAS381B
Weatherproof wall sounder bell tone	CAS381WPB
Australian internal wall sounder	CAS381AU
Australian weatherproof wall sounder	CAS381WPAU
Wall sounder beacon	CASB383
Wall sounder beacon weatherproof	CASB383WP
VAD wall sounder beacon bell tone	CASB393B
Weatherproof VAD wall sounder beacon bell tone	CASB393WPB



Addressable fire systems

Devices - beam detectors



Beam detectors, typically used in large open areas, such as airports, shopping centres and warehouses

Beam detectors

There are two available loop powered reflective beam detectors in the intelligent addressable range. The MAB50R has a range of up to 50 metres and the MAB100R has a range of up to 100 metres. Neither requires a power supply and are both equipped with a simple set up mode to enable easy and quick alignment during installation.

The beam detector is loop powered with one unique address, and has the ability to add address text at the panel. There is a maximum limit of 20 per loop (based on loop loading calculations).

Addressable reflective beam detector MAB50R / MAB100R

Dimensions

H (mm)	W(mm)	D (mm)
210	130	120

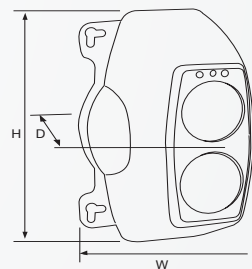
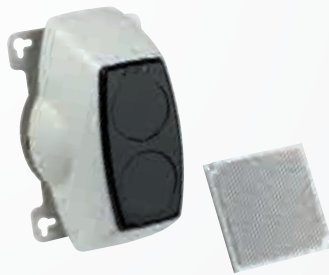

Typical applications:

Large open areas such as warehouses, manufacturing plants, shopping centres, airports etc.

Allows access to the automatic gain control data from the detector.

The beam detector will show fire, fault and pre-alarm.

Duct probe mounting kit

The presence of smoke in a ventilation duct is detected by sampling the airflow through the duct via two sampling tubes. A detector and base are mounted within the sampling chamber, which is located on the external skin of the duct, with sample and exhaust probes passing into the duct in an area of low turbulence. The unit requires an addressable optical detector and base and is supplied with full fixing instructions.

Duct probe unit MDP201



Typical applications:

Detecting presence of smoke in ventilation ducts.

Requires base and detector to be ordered separately.

Duct probe unit shown with optical detector fitted

Features

	MAB50R	MAB100R
Operating range	5 to 50 metres	50 to 100 metres
Tolerance to beam misalignment at 35%	Detector $\pm 0.8^\circ$, Prism $\pm 5.0^\circ$	Detector $\pm 0.8^\circ$, Prism $\pm 5.0^\circ$
Fire alarm thresholds	2.50dB (25%) 3.74dB (35%) 6.02dB (50%)	2.50dB (25%) 3.74dB (35%) 6.02dB (50%)
Optical wavelength	880nm	880nm

Beam detectors have 3 operating modes:

Prism targeting mode designed to provide simple initial alignment of beam and reflector assembly.

Alignment mode enables accurate fine tuning of beam alignment without the need for additional calibration equipment or a second operator.

Normal running mode during standard operation.

Features

Duct width range	300mm to 1500mm 5 to 50 metres
Duct air speed range	1m/s to 20m/s Detector $\pm 0.8^\circ$ Prism $\pm 5.0^\circ$
Temperature range	-20°C or +60°C
Optical wavelength	880nm

Catalogue numbers

Description	Code
Reflective beam detector (50m range)	MAB50R
Reflective beam detector (100m range)	MAB100R
Mounting bracket	MRBFP
Spare reflector	MABR
Duct probe unit	MDP201



Interfaces

We supply an extensive range of interfaces to support our control panels. Interfaces allow for a wide variety of installations to be simplified without the use of specialist or customised equipment. For assistance deciding which interfaces will benefit you the most, contact our technical support team at techsupport@cooperfire.com

Zone monitor unit CZMU352



Spur isolator unit CSI350



Shop monitor unit MSU840



3 channel I/O unit CIO351



Typical applications:

The unit connects a zone of suitable conventional detectors (20 detectors per zone) and a separate zone of conventional callpoints (if required) to an addressable panel.

It allows for easier connection to existing conventional detection zones, as long as the devices used are compatible.

Typical applications:

The spur isolator unit enables a spur of intelligent addressable devices to be connected to a main analogue loop. This simplifies the installation of remote parts of buildings or system extensions.

The CSI350 doesn't take an address in the number sequence.

Recommended no more than a zones worth of devices per isolator.

Typical applications:

The shop monitor unit is designed to allow small units with conventional fire systems to be fully integrated with a main intelligent addressable fire system.

It is ideal for connecting individual shop units into a main shopping centre system.

Recommended for use with conventional VADs (see p78). Please note: A PSU (see p38) is required to operate conventional sounder circuits.

The CSUM355 can have 2 sounder circuits, each with up to 0.3A of power.

Typical applications:

The 3 channel input/output unit enables simple interfacing between the fire system and other equipment such as nurse call systems or access control systems. The inputs are fully monitored for open and short circuits.

Relay contacts are rated at 30V dc 1A. See below for further options.

Dimensions

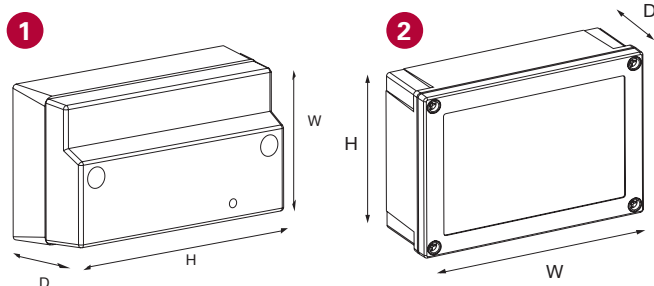

Description	H (mm)	W (mm)	D (mm)
Interface style 1 1	88	147	60
Interface style 2 2	129	180	60

Catalogue numbers

Description	Code
Zone monitor unit	CZMU352
Shop monitor unit	MSU840
Spur isolator unit	CSI350
3 channel input/output unit resets on reset (recognised as 1 address)	CIO351
3 channel input/output unit resets on reset (recognised as 3 addresses)	CIO351T
3 channel input/output unit resets on silence alarms	CIO351S
230V ac relay unit	CMIO353

**230V ac relay unit
CMIO353**



Typical applications:

Enables simple interfacing between the fire system and other equipment such as nurse call systems or access control systems.

The ability of the output unit to switch 230V ac mains at 8A makes the unit ideal for plant control or mains powered door holders.

The input is monitored for open and short circuits therefore can be used for fire input applications such as monitoring sprinkler flow switches.

If you require higher current switching (10A) please see page 82 for MAR724.

**4 to 20mA interface
CGI420**



Typical applications:

Designed to interface with gas detection modules and are compatible with Eaton intelligent addressable control panels.

The supply to the gas detector is taken directly from the interface.

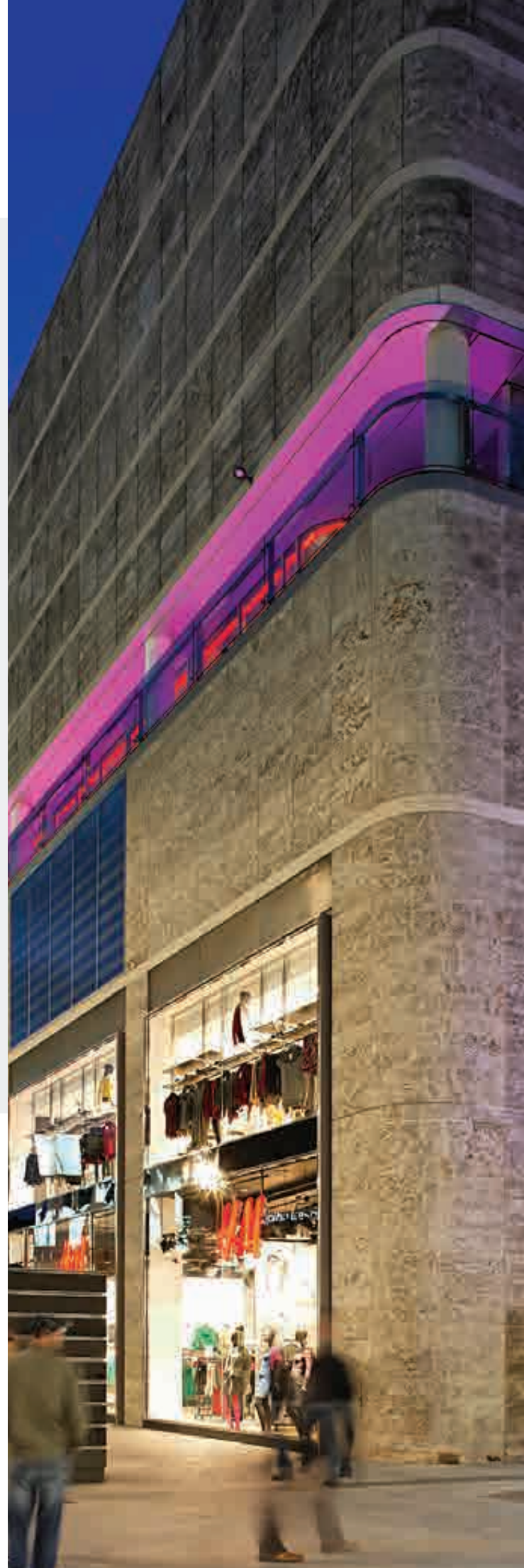

Interfaces continued

4 way sounder controller unit CSC354CPR



Typical applications:

The 4 way sounder controller unit (CSC354CPR) adds functionality to your addressable panel by powering up to 4 lines of conventional output devices.

The CSC354CPR gives access to Eaton's extensive range of conventional devices, including EN54-23 certified VADs, beacons, signboards, bells and sounders.

It is ideal in situations where there is a requirement for devices with a high current draw or where conventional sounder circuits are in a remote location away from the fire alarm control panel.

Dimensions

Description	H (mm)	W (mm)	D (mm)
4 way sounder controller Unit	300	300	74

Catalogue numbers

Description	Code
4 way sounder controller unit)	CSC354CPR

Mimic relay boards CIOP4 / CIOP8



Typical applications:

These addressable mimic relay boards (CIOP4) and (CIOP8) are 4 and 8 way soft addressing output modules, incorporating integral short circuit isolators.

The units are suitable for switching low voltage (24V dc at 1A maximum), via a set of latching relay contacts.

The flexibility of these modules is further enhanced by the fact that each output can be programmed for a range of triggers such as disablement, fault, fire, test panel, test zone prealarm, fire routing equipment, fire protecting equipment and reset with up to 16 different trigger sources per output.

These units have an additional 4 inputs which can initiate a reset, silence, evacuate and test function.

Dimensions

Description	H (mm)	W (mm)	D (mm)
CIOP4/8 mimic relay board	180	244	63

Catalogue numbers

Description	Code
Technical input/output unit	CFC301
4 way mimic relay board, 4 inputs, 4 outputs	CIOP4
8 way mimic relay board, 8 inputs, 8 outputs	CIOP8
4 to 20mA interface	CGI420

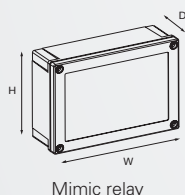

Micro interfaces

Whereas our standard interfaces are designed to be installed in the position required on the loop, our range of micro interfaces are compact enough to sit within a panels' enclosure, or in our dedicated mini module enclosure (ULBU) which can house up to 3 mini modules.

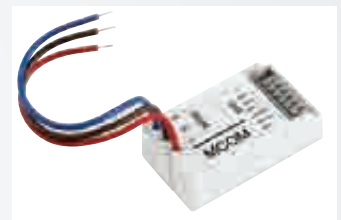
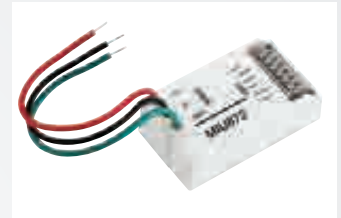
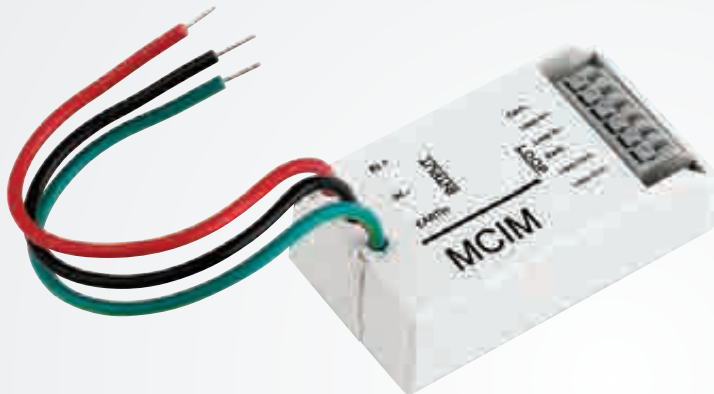

Micro zone monitor unit MIU872

Typical applications:

The micro zone monitor unit (MIU872) is suitable for interfacing a zone of up to 20 conventional detectors onto an intelligent addressable control panel.

It will operate with any conventional detector in configuration with a schottky diode type base (CDBB300).

Micro single channel input unit MCIM

Typical applications:

The micro single channel input unit (MCIM) is suitable for monitoring a set of normally open, volt free contacts such as sprinkler system flow switches and auxiliary panel fire/fault signals. Other examples include non-fire input signals such as flow valve open contacts, generator start up, fire door closed etc.

Micro single channel output unit MCOM

Typical applications:

The micro single channel output unit (MCOM) is suitable for switching low voltage (24V dc at 1A maximum), via a set of non latching relay contacts.

It is also suitable for switching HVAC control circuits, plant shutdown control circuits, fire door closure etc.

Variants

The (MCOM-R) gives a 5 second pulse on reset, and is used for connecting/resetting beam detectors.

The (MCOM-S) is identified by the panel as a sounder and does not reset when put into 'silence' mode, only resets once panel has been reset.

Installation into mini module box

1. Fit the unit in position in accordance to the mounting diagram below.
2. Connect the unit according to standard connections.
3. Up to 3 units can be fitted inside a micro module box unit

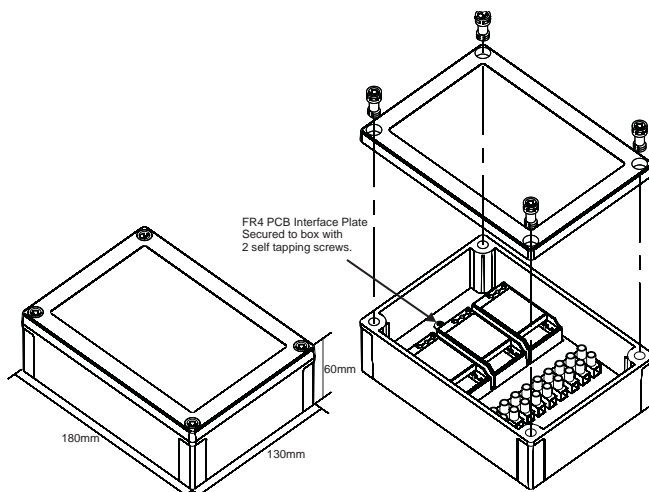

Features

	MIU872	MCOM	MCIM
Soft addressed	✓	✓	✓
Short circuit isolators	✓	✓	✓
Single address	✓	✓	✓

Catalogue numbers

Description	Code
Micro zone monitor unit	MIU872
MCOM Output Module	400010FIRE-0024X
MCOM-S Output Module Sounder	400012FIRE-0026X
MCOM-R Output Module Resettable	400011FIRE-0025X
MCIM Micro single channel input unit	400008FIRE-0022X
Mini module box unit (empty box)	ULBU



Network interfaces

Eaton offer multiple network interfaces which allow our panels and devices a wider variety of functionality. These network interfaces allow the connection of the Eaton network system to a computer network, and PC based applications such as site monitor, site graphic and web server.

Lon to RS232 adaptor EC0232



Typical applications:

The EC0232 Lon to RS232 adapter allows connection of our system network (LonWorks) devices to PC based applications such as site monitor, site graphics and web server.

In addition to the standard adaptor, Eaton offer 2 variants for use with a HMX PA/VA system - the ECO232PAVA with no handshaking, and the ECO232PAVA3D with a 3 min time delay.

Dual-channel LonWorks BMS interface EC200



Typical applications:

The EC200 dual-channel LonWorks BMS interface is an "add-on" to the network which translates the pre-configured network variables to a set of un-configured network variables which can then be bound to a BMS, giving full access to the fire network data.

TCP/IP interface EC400



Typical applications:

The EC400 is a high performance, reliable and secure network infrastructure device for accessing Eaton Lon Network of intelligent addressable control panels over intranet or ethernet.

The EC400's built in configuration server manages up to 256 IP devices on 1 IP channel without a dedicated management PC.

Easy to understand diagnostic LEDs allow installers to install and troubleshoot the device without expert knowledge and dedicated troubleshooting tool.

Lon network booster EC540



Typical applications:

The Lon network booster (EC540) is the solution to interconnect multiple EIA-709 channels.

This unit provides up to 5 ports and routes packets between these ports. In spite of its small size the (EC540) provides best class performance and flexibility in use.

In order to provide the optimal router configuration the (EC540) supports 2 to 5 ports as well as the 2 operating modes "smart switch mode" and "configured router mode".

Fibre optic multi-drop link - example network diagram

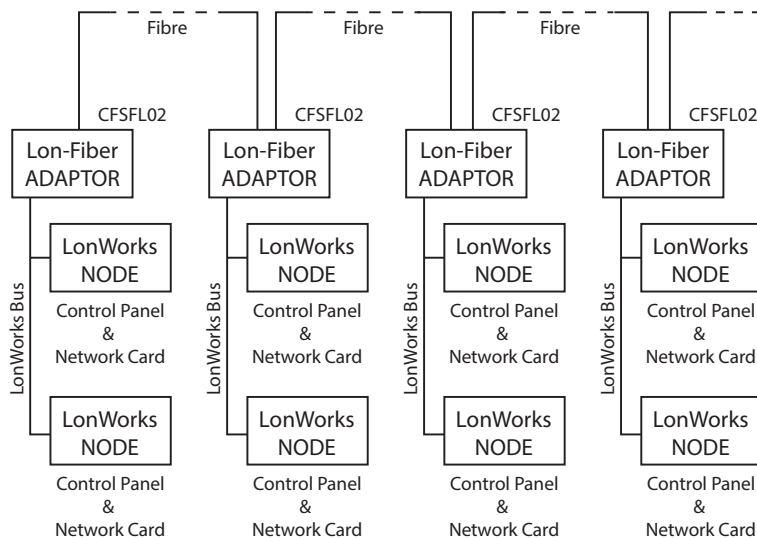

BACnet gateway EC650B



Typical applications:

The BACnet gateway (EC650B) is a CEA-709/BACnet gateway which maps CEA-709 network variables (NVs) to standard BACnet server objects. When ordered with this part code (EC650B), the LonWorks to BACnet address mapping is pre-loaded and ready for use with the intelligent addressable CF3000 system interface board.

Modbus gateway EC700



Typical applications:

The modbus gateway is part of the InfraLINK range of network infrastructure components from partners. All of the modbus gateways feature a robust hardware platform with high performance CPU and UART for fast communications without loss of data. The LonWorks to modbus address mapping is pre-loaded and ready for use with the CF3000 fire system interface board.

Single mode Lon to fibre optic adapter CFSFL01



Typical applications:

The single mode Lon to fiber optic adapter (CFSFL01) allows connection of the system network (LonWorks) devices through optical fibre, and to allow both point to point or multi drop topology.

Dual channel Lon to fibre optic adapter CFSFL02



Typical applications:

The dual channel Lon to fiber optic adapter (CFSFL02) allows connection of the system network (LonWorks) devices through optical fibre, and to allow both point to point or multi drop topology.

Catalogue numbers

Description	Code
Dual-channel lonworks BMS interface (non handshake)	EC200
Dual-channel lonworks BMS interface (handshaking)	EC200H
Dual-channel lonworks BMS interface (self configuring for use with EC700)	EC200S
Lon to RS232 adapter	EC0232
Lon to RS232 adapter (For HMX pa/va system - no handshake)	EC0232PAVA
Lon to RS232 adapter (For HMX pa/va system - 3 min time delay)	EC0232PAVA3D

Description	Code
TCP/IP interface	EC400
Lon network booster	EC540
Bacnet gateway	EC650B
Modbus gateway	EC700
Single mode lon to fibre optic adaptor	CFSFL01
Dual channel lon to fibre optic adaptor	CFSFL02

Intelligent addressable systems

Devices - ancillaries

Ancillaries

A range of ancillaries are available to complement and extend the capability of our existing hardware.

Loop splitter unit ZPCB2222



Typical applications:

Allows expansion of the CF3000 intelligent addressable panel from 4 to 16 loops.

This interface is mainly applicable in countries where the mixing of detectors, sounders, callpoints and interfaces are not permissible on the same loop or the number of devices per loop is limited to a small number.

Mimic PCB ZPCB2252MML / ZPCB2252MSL

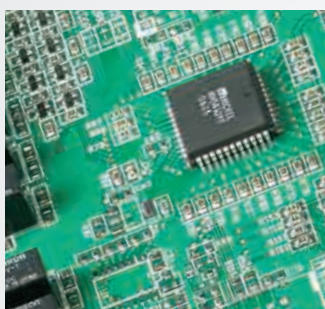

Typical applications:

Up to 250 outputs can be connected to the mimic PCBs (ZPCB2252MML) and (ZPCB2252MSL). This offers more capability to the extensive options already offered by the CF3000 control panel.

These boards are typical used for geographical LED mimic displays.

SPS Range - SPS-2423 SPS-2433 SPS-2453



Typical applications:

Offers a compact, robust and versatile power solution to installers, allowing them to safely power fire detection and signaling systems in small to large installations.

Compact and discrete design allows for these SPS to be installed in a visible location such as a hotel lobby for instance.

Catalogue numbers

Description	Code
Loop splitter unit	ZPCB2222
Mimic PCB (master)	ZPCB2252-MML
Mimic PCB (slave)	ZPCB2252-MSL
Safety power supply 24V / 1.5A (batteries not supplied)	SPS-2423
Safety power supply 24V / 2.5A (batteries not supplied)	SPS-2433
Safety power supply 24V / 4.5A (batteries not supplied)	SPS-2453

Intelligent addressable systems

Devices - software and testing equipment

Software

Eaton offer a number of specialised programs to aid with the installation, maintenance, functionality and servicing of our addressable systems. Installed using the USB analogue systems panel interface (see p41) and a PC or laptop, these software programs help to solidify our addressable systems' capabilities and make it easier for users to control and organise the system on their site.



Graph pack software GRAPHPACK



Typical applications:

Graph pack software is a powerful alarm management tool and graphical user interface designed to work with many of Eaton's fire system products.

Users can monitor, control and interrogate their systems to ensure alarms are detected and dealt with quickly and efficiently.

Site monitor SITEMONITOR



Typical applications:

Site monitor / webservice software is designed to monitor Eaton fire systems and allow quick PC based administration.

Using a simple interface, authorised users can view control panel event history, event status, device properties and other information depending on access permissions defined by the system administrator.

Catalogue numbers

Description	Code
Graph pack software (lite)	GRAPHPACK1-2LITE
Graph pack software (1 panel)	GRAPHPACK1
Graph pack software (2-5 panels)	GRAPHPACK2-5
Graph pack software (6-10 panels)	GRAPHPACK6-10
Graph pack software (11-20 panels)	GRAPHPACK11-20
Graph pack software (21-99 panels)	GRAPHPACK21-99
Graph pack software (21-127 panels)	GRAPHPACK21-127
Graph pack and site monitor	GRAPHSITEMON
Site monitor / webservice software	SITEMONITOR

All software products except SITEMONITOR include EC0232 (p36) as standard

Testing equipment

As well as offering complete fire systems, Eaton can also provide testing equipment to ease the process of installation, commissioning, maintenance and fault finding.

Loop tester kit LP800KIT



Typical applications:

The loop tester kit is a hardware/software combination that can be used to test, commission and fault find a loop of up to 200 intelligent addressable devices (sensors, sounders, ancillary devices) without having to connect the loop to the intelligent addressable control panel.

The loop tester is connected between the loop and PC, and allows the engineer to quickly identify and locate any loop device that is operating outside its operating conditions.

USB analogue systems panel interface USBINT2



Typical applications:

The analogue systems panel interface is a universal serial bus converter that provides conversions from RS232 to USB, TTL to USB or TTL to RS232.

These options provide the connectivity required between a PC and intelligent addressable control panels, wireless control panels, and wireless survey tools including our range of software solutions (see page 40).

Addressable device programmer CF800PROG



Typical applications:

The addressable device programmer is a versatile tool to aid the installation, commissioning, maintenance and servicing of current intelligent addressable devices and fire systems.

This unit is light, robust and easy to operate using a user friendly menu structure on 2 x 40 character LCD display. It is powered from a single PP3 size, heavy duty battery or an external supply.

CF800PROG can:

Program sensor modes (see p24).

Change address details

Change heat detector settings

Read analogue levels

Catalogue numbers

Description	Code
Loop tester kit	LP800KIT
Addressable device programmer	CF800PROG
USB panel interface	USBINT2



UL Systems

Underwriters Laboratories Inc. (UL) is an independent product safety certification organisation, established in 1894, to develop standards and test procedures for products, materials, components, assemblies, tools and equipment. Chiefly dealing with product safety it also evaluates and certifies the efficiency of a company's business processes through its magnificent system registration programs.

Since the launch of our UL Listed fire product range, several prestigious projects worldwide have been supplied including Hyatt Resort and Spa,

Shangri-la at the Fort and Times Square projects in South East Asia and several major projects in the Middle East including a major projects within the prestigious Riyadh Financial District in the Kingdom of Saudi Arabia.

The Eaton UL range is designed to provide a solution for all sizes of project, from the simple small stand alone system to the large multi panel networked system with PAVA and BMS integration.

Contents

UL listed fire systems range

Panels

ULCF3000 series panels **44**



Devices

Addressable sensors **46**



Conventional detectors **48**



Horns and strobes **50**



Pull stations **52**



Interfaces **54**



Micro interfaces **55**



ULCF3000 series

UL listed control panels



ULCF3000RM (wall mount red metal)



ULCF3000 (wall mount graphite)

The ULCF3000 series panels are UL listed, high specification, wall or rack mounted fire panels. Combining sophisticated functionality with simple operation and aesthetically pleasing design, the panels are available in a number of loop configurations. Each panel is networkable with up to 126 other Eaton UL fire panels.

The control panel has the ability to support complex cause and effect programming. A wide range of user controllable functions make the system ideal for a diverse range of projects, from industrial applications through to large multi-site commercial developments.

Benefits

- Soft addressing
- Large versatile touchscreen user interface
- Integral printer (optional)
- Integral battery and power supply
- 2 x 12Ah batteries included
- Flexible distributed network capability
- Full range of compatible devices
- 4 notification appliance circuits (NACs) outputs
- 2 or 4 class A style 7 SLC loops
- PAS (Positive Alarm Sequence)



Dimensions

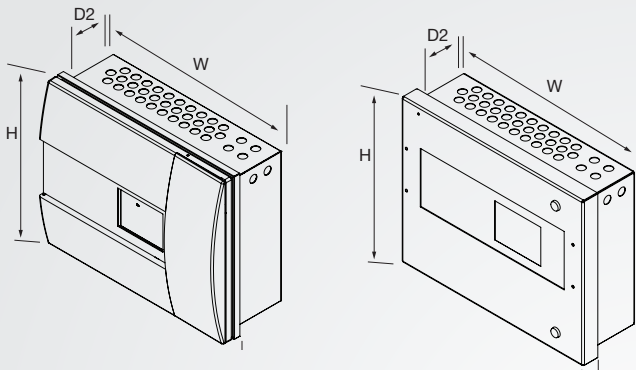

Description	H (mm)	W (mm)	D1 (mm)	D2 (mm)
ULCF3000	397	497	75	130
ULCF3000RM	398	505	48	118



Compatible repeater panels

The ULCF3000 has both a standard and a touchscreen repeater panel available. Ideal for larger sites, the repeater allows you to display the system information from multiple locations.



Features

	ULCF3000PRG	ULCTPR3000
Active or passive option	x	✓
No programming required	✓*	✓
Multi language capability	x	✓
Allows networking with other Eaton fire panels	x	✓
Integral power supply	✓	✓

*Except local text information



Catalogue numbers

Description	Code
2 loop panel	ULCF30002G
4 loop panel	ULCF30004G
2 loop panel, integral printer	ULCF30002GP
4 loop panel, integral printer	ULCF30004GP
2 loop panel, network card	ULCF30002GNC
4 loop panel, network card	ULCF30004GNC
2 loop panel, integral printer, network card	ULCF30002GPNC
4 loop panel, integral printer, network card	ULCF30004GPNC
2 loop panel, red metal box	ULCF30002GRM
4 loop panel, red metal box	ULCF30004GRM
2 loop panel, integral printer, red metal box	ULCF30002GPRM

Description	Code
4 loop panel, integral printer, red metal box	ULCF30004GPRM
2 loop panel, network card, red metal box	ULCF30002GNCRM
4 loop panel, network card, red metal box	ULCF30004GNCRM
2 loop panel, integral printer, network card, red metal box	ULCF30002GPNCRM
4 loop panel, integral printer, network card, red metal box	ULCF30004GPNCRM
Rack mounted 2 loop panel	ULR3000L2
Rack mounted 4 loop panel	ULR3000L4
Rack mounted 2 loop panel c/w network card	ULR3000L2NC
Rack mounted 4 loop panel c/w network card	ULR3000L4NC
Loop connected repeater panel	ULCF3000PRG
Touchscreen network repeater panel	ULCTPR3000

UL intelligent addressable systems

Devices - addressable sensors

Sensors

Our UL range has multiple options for intelligent addressable sensors. All sensors are designed for optimum functionality in mid-large sized builds. They are all soft addressed and have integral short circuit isolators.

Addressable sensor base UCAB300



Typical applications:

Specifically designed for use with all of our UL addressable sensors, the UCAB base will be used in all builds.

Optical smoke sensor ULCAP320



Typical applications:

Suitable for most applications. Fastest response to slow burning or smouldering fires which give rise to large visible smoke particles.

Photo-thermal sensor ULCAPT340



Typical applications:

Responds quickly to fast clean burning fires. Maintains the advantage of optical sensors when detecting smouldering fires.

Heat sensor ULCAH330



Typical applications:

Environments where the ambient conditions might cause false alarms with smoke detectors. Examples include areas with high levels of dust or fumes.



Sensor detail



Addressable base detail

Performance

Heat Class	ULCAP320	ULCAPT340	ULCAH330
Heat element rating	N/A	135°F	ROR + Fixed 135°F, Fixed 135°, Fixed 194°F
Heat detector spacing	N/A	50ft (heat alone operation)	50ft
Heat class	N/A	A2S	A2R

Dimensions

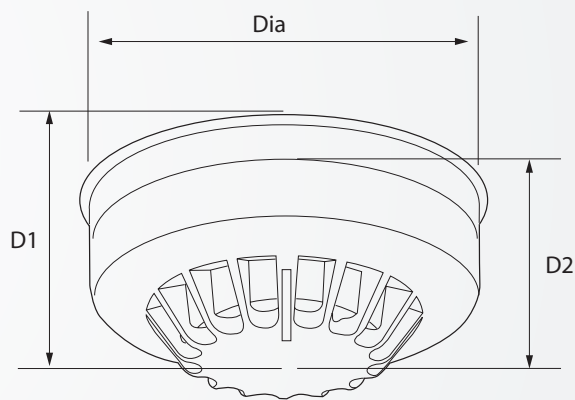

Description	Diameter (mm) (incl base)	Depth (mm) (excl base)	Depth (mm) (incl base)
Optical	104	33	45
Photo-thermal	104	43	55
Heat	104	43	55

Catalogue numbers

Description	Code
ULCAP320 Optical smoke sensor	400005FIRE-0011X
ULCAPT340 Photo-thermal sensor	400006FIRE-0012X
ULCAH330 Heat sensor	400007FIRE-0013X
Addressable sensor base	UCAB300



UL intelligent addressable systems

Devices - conventional detectors

Detectors

Our UL range has multiple options for conventional detectors. All detectors have a removable detector chamber and drift compensation. The range of detectors for different applications allow for all build requirements to be met.

As there is no UL certified conventional panel a ULMIU872 micro interface (page 55) is required in conjunction with a UL intelligent addressable panel to use conventional detectors.

Optical smoke detector

UCPD-2W



Typical applications:

Suitable for most applications.

Fastest response to slow burning or smouldering fires which give rise to large visible smoke particles.

Photo-thermal detector

UCPT-2W



Typical applications:

Responds quickly to fast clean burning fires.

Maintains the advantage of optical sensors when detecting smouldering fires.

Fixed heat detector (135°F)

UCHT-2W



Typical applications:

Environments where the ambient conditions might cause false alarms with smoke detectors.

Examples include areas with high levels of dust or fumes.

Additional heat detector options

Code

UCHTI-2W:
Fixed heat, 194°F detector

UCHR-2W:
Rate of rise & fixed heat 135°F

UCHRI-2W:
Rate of rise & fixed heat 194°F

Performance

Heat class	UCPD-2W	UCPT-2W	UCHT-2W	UCHTI-2W	UCHR-2W	UCHRI-2W
Heat element rating	N/A	135°F	135°F	194°F	135°F	194°F
Heat detector spacing	N/A	50ft (heat alone operation)	50ft	50ft	50ft	50ft
Mounting position	Ceiling in open areas	Ceiling in open areas	Ceiling in open areas	Ceiling in open areas	Ceiling in open areas	Ceiling in open areas

Conventional detector base CB2E



Typical applications:

The CB2E has been specifically designed for compatibility with our UL range of conventional detectors. It can be used in all builds with conventional detectors.



Dimensions

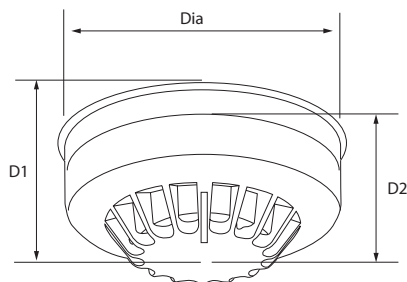

Description	Diameter (mm) (incl base)	Depth (mm) (incl base)	Depth (mm) (excl base)
Optical	104	45	33
Photo-thermal	104	55	43
Heat	104	55	43

Catalogue numbers

Description	Code
2 wire detector, optical	UCPD-2W
2 wire detector, opto-heat	UCPT-2W
2 wire detector, fixed heat 135°F	UCHT-2W
2 wire detector, fixed heat 194°F	UCHTI-2W
2 wire detector, rate of rise and fixed heat 135°F	UCHR-2W
2 wire detector, rate of rise and fixed heat 194°F	UCHRI-2W
Standard detector base	CB2E

Horns and strobes

Our UL range incorporates a variety of audio and visual notification devices. Each device has up to 48% savings in current draw compared to similar products. The whole range is easy to install and has voltage test points for quick troubleshooting and easy spot checking, saving time on both installation and maintenance.

Wall mount horn
CN126292



Ceiling mount horn
CN128972



Wall mount horn strobe/synchronised strobe
CN127249/CN127380



Ceiling mount horn strobe/synchronised strobe
CN127464/CN127488



Typical applications:

The horns are ideal for retrofit jobs, limited space environments and pre-existing wire configurations.

Typical applications:

The horns are ideal for retrofit jobs, limited space environments and pre-existing wire configurations.

Typical applications:

With the range of settings for both audio and visual purposes, these products are effectively 9 models in 1 appliance. With this functionality, and both ceiling and wall mount options available, it will meet almost any build requirements.

The synchronised option enhances both the sound and light output by keeping the outputs of multiple devices in sync.

Dimensions

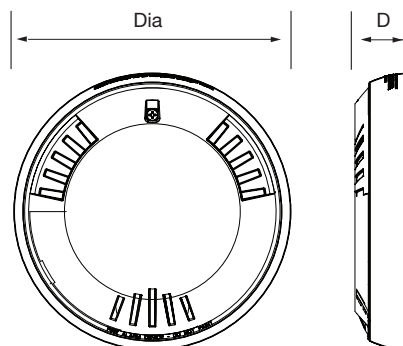
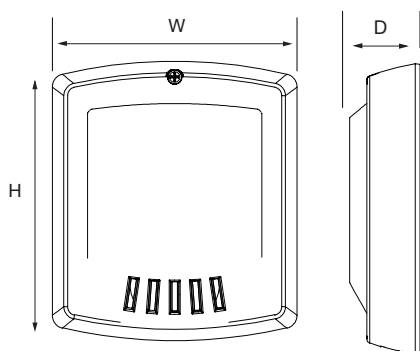

Description	H (mm)	W (mm)	D (mm)
Wall mount horn CN126292	133	116	56
Wall mount horn strobe/ synchronised strobe CN126292/CN127380	131	131	110

Description	Diameter (mm)	Depth (mm)
Ceiling mount horn CN128972	166	34
Ceiling mount horn/ synchronised strobe CN127464/CN127488	166	34

Wall mount outdoor synchronised strobe CN129013



Ceiling mount outdoor synchronised strobe CN124338



Typical applications:

The outdoor synchronised strobes are UL certified to meet adverse weather conditions. They are perfect for builds where outdoor indication is required.

These units use a universal, common mounting base making them ideal for retrofit jobs, limited space environments and pre-existing wire configurations.



Dimensions

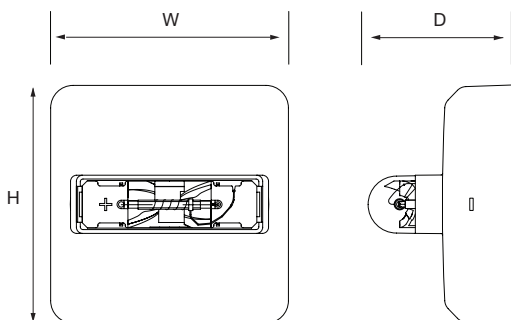

Description	H (mm)	W (mm)	D (mm)
RSSWP*	131	131	110

*Both wall mount and ceiling mount variants

Catalogue Numbers

Description	Code
Wall mount horn	CN126292
Ceiling mount horn	CN128972
Wall mount horn strobe	CN127249
Ceiling mount horn strobe	CN127464
Wall mount synchronised strobe	CN127380
Ceiling mounted synchronised strobe	CN127488
Wall mount outdoor synchronised strobe	CN129013
Ceiling mount outdoor synchronised strobe	CN124338
WPSBB -R Exposed conduit, surface mount back box (RED)	CN109751
WPSBB -R + WP-KIT Concealed conduit surface mount back box (RED)	CN109751 + CN104486

Pull stations

The addressable pull stations are constructed of high quality, die cast metal for long lasting performance. The range consists of the UL listed MPS range of pull stations and the UL listed fast response input initiating module (ULMCIM-C).

Single action addressable pull station

UMPS-100/
UMPS-100WP



Typical applications:

Indoor/weatherproof pull station for use with addressable systems (UMPS-100/UMPS-100WP).

A dual action model is also available (UMPS-200, not shown), where the push bar rotates inward allowing the pull handle to be grasped in a one handed motion.

Single action conventional pull station

SG42BK2



Typical applications:

Cost effective conventional version of the single action pull station, must be used in conjunction with ULMIU872. **Back box ordered separately.**



Pull station detail

Dimensions

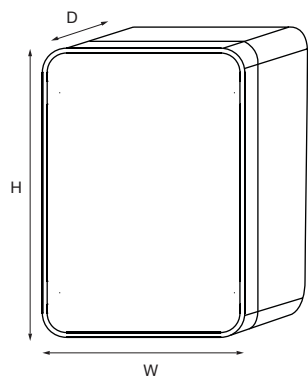

H (mm) W (mm) D (mm)

118 80 80

Catalogue numbers

Description	Code
Single action pull station, supplied with back box (addressable)	UMPS-100
Weatherproof single action pull station	UMPS-100WP
Double action pull station	UMPS-200
Weatherproof double action pull station	UMPS-200WP
Micro zone monitor unit	ULMIU872
Micro single channel input unit (recognised as callpoint)	ULMCIM-C
Conventional single action pull station (back box ordered separately)	SG42BK2
Conventional double action pull station (back box ordered separately)	SG42BK1
Back box for conventional, surface mounting	SGB32S
Back box for conventional, weatherproof	SGB-32C



Interfaces

We supply an extensive range of interfaces to support our UL control panels. Interfaces allow for a wide variety of installations to be simplified without the use of specialist or customised equipment. For assistance deciding which interfaces will benefit you the most, contact our technical support team; techsupport@cooperfire.com

4 Way Sounder Controller Unit ULCSC354



Typical applications:

The unit connects a zone of suitable conventional detectors and a separate zone of conventional callpoints (if required) to an addressable panel.

It allows for easier connection to existing conventional detection zones, as long as the devices used are compatible.

Shop monitor unit ULCSUM355



Typical applications:

The shop monitor unit is designed to allow small units with conventional fire systems to be fully integrated with a main intelligent addressable fire system.

It is ideal for connecting individual shop units into a main shopping centre system.

Spur isolator unit ULCSI350



Typical applications:

The spur isolator unit enables a spur of intelligent addressable devices to be connected to a main analogue loop. This simplifies the installation of remote parts of buildings or system extensions.

3 channel I/O unit ULCIO351



Typical applications:

The 3 channel input/output unit enables simple interfacing between the fire system and other equipment such as nurse call systems or access control systems. The inputs are fully monitored for open and short circuits.

230V ac relay unit ULCMIO353



Typical applications:

Enables simple interfacing between the fire system and other equipment such as nurse call systems or access control systems.

The ability of the output unit to switch mains also makes the unit ideal for plant control or mains powered door holders.

The input is monitored for open and short circuits so can be used for fire input applications such as monitoring sprinkler flow switches.

Dimensions

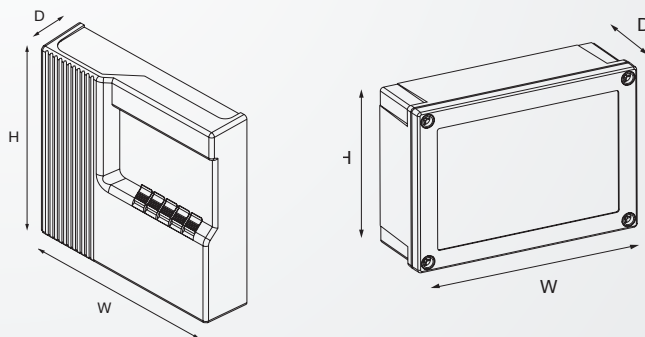

Description	H (mm)	W (mm)	D (mm)
Interface units	129	180	60
4 way sounder controller unit	300	300	74

Micro interfaces

Whilst our standard UL interfaces are designed to be installed in the position required on the loop, our range of micro interfaces can sit within a panels' enclosure.

Micro single channel output units ULMCOM/ULMCOM-S



Typical applications:

The Micro Single Channel Output Unit (ULMCOM) is suitable for switching low voltage (24V dc at 1A maximum), via a set of non latching relay contacts.

It is also suitable for switching HVAC control circuits, plant shutdown control circuits, fire door closure etc.

The ULMCOM-S is identified by the panel as a sounder.

Micro single channel input units ULMCIM/ULMCIM-C



Typical applications:

The Micro Single Channel Input Unit (ULMCIM) is suitable for monitoring a set of normally open, volt free contacts such as sprinkler system flow switches and auxiliary panel fire/fault signals. Other examples include non-fire input signals such as flow valve open contacts, generator start up, fire door closed etc.

The ULMCIM-C is identified by the panel as a call point and is designed for use with pull stations.

Micro zone monitor unit ULMIU872



Typical applications:

The Micro Zone Monitor Unit (ULMIU872) is suitable for monitoring a zone of up to 20 UL approved conventional detectors.

Dimensions

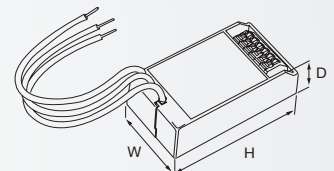

H (mm)	W (mm)	D (mm)
65	35	18.5

Please be aware, we offer an enclosure for our micro interfaces, see p35.

Catalogue numbers

Description	Code
4 way sounder controller unit	ULCSC354
Shop monitor unit	ULCSUM355
Spur isolator unit	ULCSI350
3 Channel input/output unit resets on reset	ULCIO351
3 Channel input/output unit rests on silence alarms	ULCIO351S
120V/230V ac relay u.nit	ULCMIO353
Micro zone monitor unit	ULMIU872

Description	Code
ULMCOM Micro single channel output unit (recognised as output unit)	400015FIRE-0029X
ULMCOM-S Micro single channel output unit (recognised as sounder)	400016FIRE-0030X
ULMCIM Micro single channel input unit (recognised as input unit)	400013FIRE-0027X
ULMCIM-C Micro single channel input unit (recognised as callpoint)	400014FIRE-0028X
Mini module box unit (empty box)	ULBU



Contents

Two-wire and conventional fire systems

Two-wire fire system

BiWire Ultra controls panels **58**



BiWire Ultra devices **60**



Two-wire and conventional fire system

BiWire Flexi controls panels **62**



Conventional fire system

EFCV8 series panel **64**



FXP2200 series panel **68**



FXP5000 series panel **70**



Conventional devices

Detectors and indicators **72**



Bases **74**



Beam detectors **72**



Duct probe detector **73**



Callpoints **74**



Bells **75**



Sounders **76**



Visual alarm devices **78**



Indicators **80**



Sounder indicators **81**



Door retainers **82**



Auxiliary power supply **83**



EFBW series

BiWire Ultra control panel



“Two-wire panel, offering significant cable and install cost savings without sacrificing performance”

Eaton’s BiWire Ultra fire detection system, available in 2, 4 and 8 zone, is unlike any other standard conventional system as the panel, detectors, sounders and EN54-23 approved beacons all share the same zone wiring. This delivers significant savings in both cable and installation costs without sacrificing the systems capability.

Testing is simple, it only takes one person to review and ensure the healthy state of the system.

Its modern design and simple interface makes it an ideal choice for small businesses, primary schools, retail stores, restaurants and small nursing homes.

	EFBW2ZONE	EFBW4ZONE	EFBW8ZONE
No. of zones	2	4	8
Detectors per zone	32	32	32
Maximum loading per zone	200mA	200mA	200mA
Repeater Port	✓	✓	✓

Features

- Detectors and sounders share the same wiring
- One man test facility
- Class change input
- Interlink relay functionality for connecting 2 BiWire Ultra panels together

Benefits

- Reduced cost of installation
- Simple system testing by a single fire alarm technician
- Capability to sound class change bell in schools
- Interlink relay allows for greater system flexibility
- Comprehensive protection for safety of building occupants



Dimensions

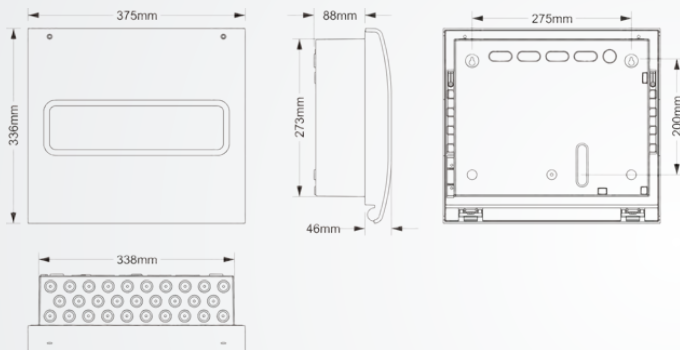

Description	Height (mm)	Width (mm)	Depth (mm)
Complete Panel	336	375	134
Backbox	273	338	88

Catalogue numbers

Description	Code
2 zone BiWire Ultra panel	EFBW2ZONE
4 zone BiWire Ultra panel	EFBW4ZONE
8 zone BiWire Ultra panel	EFBW8ZONE
Repeater panel	EFBWREPEATER



Compatible devices

Eaton's BiWire Ultra System can support up to 416 devices* in total. Certified to EN54 parts 2 and 4 it is designed to meet the recommendations in BS5839.

The new BiWire Ultra system offers innovative devices with the latest technology, including a unique set of beacons that comply with EN54-23, the latest beacon standard.

*8 Zone panel

Wall sounder VAD EF009SB



Weatherproof variant

Features

- Certified to EN54-3 and EN54-23
- High sound output and durable design
- Weatherproof option

Benefits

- Certified for Fire use
- Ideal for high noise environments
- Suitable for open areas, as well as outdoor use
- Easy to maintain and service

Dimensions

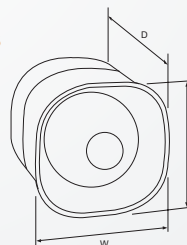

Description	H (mm)	W (mm)	D (mm)
Wall sounder VAD	110	110	100
Weatherproof	106	106	91

Base sounder and base sounder VAD

EF5021BWS / EF5021BWSB

Features

- Available in both sounder only and sounder VAD
- Certified to EN54-3 & EN54-23
- Standalone base sounder or base sounder VAD offers the flexibility of use with or without the detector
- Cover plate (optional)

Benefits

- First fix base, offers a compact design and reduces time of installation of the base with the detector
- Easy to maintain and service

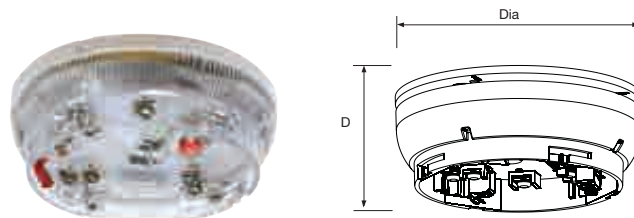

Description	Dia (mm)	D (mm)
Base sounder and base sounder VAD	115	44

5 in 1 Detector EFBW5IN1DET

Features

- Five modes in one detector
- Offers a range of sensor types
- 360° indicator LED using lightpipe technology
- Quick and simple to install
- Easy to maintain/service

Benefits

- Suitable for a broad range of applications
- Wide viewing angle for increased LED visibility
- Positive “lock” indication
- Discreet design for incorporation into any decor

Dimensions

Description	Diameter (mm) (incl base)	Depth (mm) (incl base)	Depth (mm) (excl base)
5 in 1 Detector	104	55	42

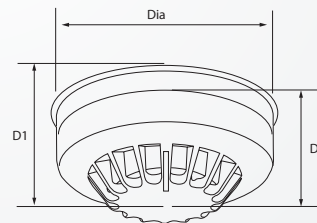

Surface/flush and weatherproof callpoint EF201BWCP / EF203BWCPWP

Features

- Fast fit clip on front cover
- Heavy duty terminals
- Two models available:
 - Internal
 - Weatherproof (IP65)
- Single tool for test and access
- Robust construction

Benefits

- Quick and simple to install
- Easy to maintain and service
- Versatile installation
- Weatherproof variant suitable for outside use

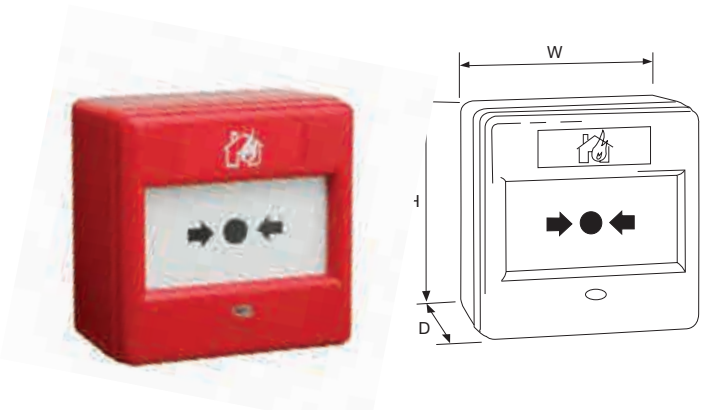

Description	H (mm)	W (mm)	D (mm)
Flush mounted	87	87	36
Surface mounted	87	87	57
Weatherproof	87	87	59

Catalogue numbers

Description	Code
Wall sounder	EF009
Wall sounder, weatherproof	EF009WP
Wall sounder VAD	EF009SB
Wall sounder VAD, weatherproof	EF009SBWP
BiWire Ultra base sounder first fix	EF5021BWS
BiWire Ultra base sounder VAD first fix	EF5021BWSB
Standard base	FXN520
Detector 5 in 1	EFBW5IN1DET

Callpoint	EF201BWCP
Callpoint weatherproof	EF203BWCPWP
External Relay 24V	BWEXTR24V
External Relay 230V	BWEXTR230V
2 Zone Option Board	BWOB2Z
4 Zone Option Board	BWOB4Z
8 Zone Option Board	BWOB8Z

EFBW series

BiWire Flexi control panel



BiWire Flexi combines two technologies to provide a truly versatile fire safety solution.

The panel can be configured to allow either two-wire or conventional devices to work on a zone. Each zone is individually configurable so a mixture of types can therefore be installed on the same system. This provides the flexibility to utilise all the time-saving benefits of a two-wire system with the ability to use a wide range of conventional devices, where required.

The BiWire Flexi fire alarm system is certified to EN54 part 2 and part 4 and is designed to meet the recommendations of BS5839.

Features

- Configure zone wiring to work as either a conventional or two-wire system
- Available in 2, 4 and 8 zone variants
- Allows the connection of an existing conventional system to a BiWire system
- Compatible with two-wire and conventional EN 54-23 certified visual alarm devices (VADs)

Benefits

- Reduces stock-holding and enables the fire system to adapt to the demands of the customer or application
- Can be used in a wide variety of applications and is very simple to install
- Save time, money and effort when undertaking system extensions and upgrades

Dimensions

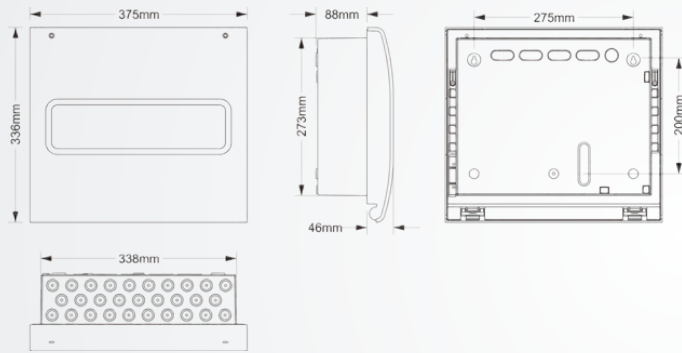

	H (mm)	W (mm)	D (mm)
Complete Panel	336	375	134
Back Box	273	338	88-

Catalogue numbers

Description	Code
2 zone BiWire Flexi panel	EFBW2ZFLEXI
4 zone BiWire Flexi panel	EFBW4ZFLEXI
8 zone BiWire Flexi panel	EFBW8ZFLEXI
2 zone relays + FRE/FPE	BWOB2Z
4 zone relays + FRE/FPE	BWOB4Z
8 zone relays + FRE/FPE	BWOB8Z
BiWire End of line module	BWEOLM-3
Conventional End of line module	EOLM-1
12V, 5Ah battery (1pc*) *2 required	MB512



EFCV8Z

Conventional control panel



Eaton's 8 zone conventional fire system panel delivers a straightforward, intuitive interface that makes programming and maintenance simple.

Approved to EN54-2&4, it offers a comprehensive set of functionalities in a modern, robust and discrete enclosure. It's appearance and performance makes the panel well suited for life safety notification in a wide variety of small to medium sized buildings, particularly schools, warehouses, retail stores and office buildings.

With the addition of an isolator barrier the panel has the additional flexibility to monitor standard or

intrinsically safe conventional zone circuits, making it suitable for industrial applications.

Benefits

- Zones switchable between standard conventional and intrinsically safe zones (using isolator barrier)
- One man test facility
- Class change input
- Interlink relay functionality for connecting 2 panels together
- Interlink relay allows for greater system flexibility
- Supports an expansion card for Fire Routing Equipment, Fire Protection Equipment and fire relays per zone
- Modern and discreet enclosure

EFCV8ZONE

No. of zones	8
Detectors per zone	32
Maximum loading per zone	32mA
Repeater Port	✓
No. of sounder circuits	4
Maximum loading per sounder circuit	250mA



Dimensions

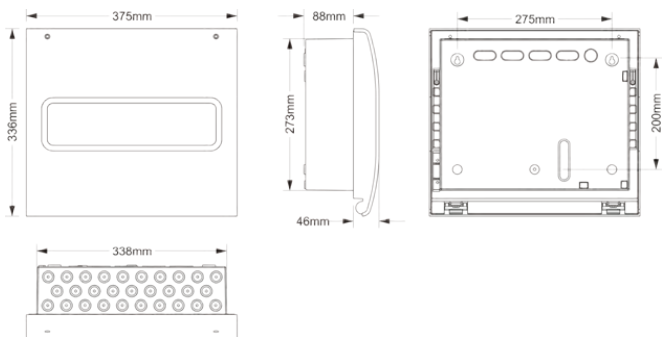

	H (mm)	W (mm)	D (mm)
Complete Panel	336	375	134
Back Box	273	338	88

Catalogue numbers

Description	Code
Eaton 8 Zone Conventional Panel	EFCV8Z
End of Line Module	EOLM-1
8 Zone Relays + FRE/FPE	BW0B8Z

FX2200CPD series

Conventional control panel



“A flexible conventional solution that ensures ease of use and high reliability”

The FX2200CPD range of conventional control panels provide a solution to any conventional system requirement. The advanced features include a simple “one-shot” user test facility, class change contacts, battery voltage alarms and charger temperature compensation, all included as standard to ensure ease of use and high reliability.

Attention to detail is emphasised by the neat log book holder feature, allowing essential records to be stored close to hand, ready for quick reference. For larger installations, custom configuration of the panels offers even greater flexibility, allowing

project specific requirements to be easily met, in a competitive and cost effective package.

Benefits

- Compact design
- Surface or semi-flush mounting
- Numerical access code (no lost keys)
- 2 or 4 zones panels
- Flexible, high specification system
- Simple “one-shot” auto-reset user test facility
- Maintenance free poly switch circuit protection, with auto reset

	FX2202	FX2204
No. of zones	2	4
Detectors per zone	32	32
No. of alarm circuits	2 (4 on FX2202CR)	2 (4 on FX2204CR)

Compatible Repeater Panel

To complement the FX2200 range a repeater panel is available for connection to the 4 zone control panel. Specifically designed for ease of installation, it requires only 2 interconnecting wires from the main panel, saving material cost and labour time. Further repeater panels can be cascaded which does not affect standby time as each has its own mains supply and standby battery. The repeater displays all the same functions as the main panel and includes an indicator test facility.

Features

- Charger with built in temperature compensation
- Displays essential information at other key locations in a large building/site
- Zone fire and fault conditions
- Test mode in operation
- Zones or alarm lines in disabled mode



Dimensions

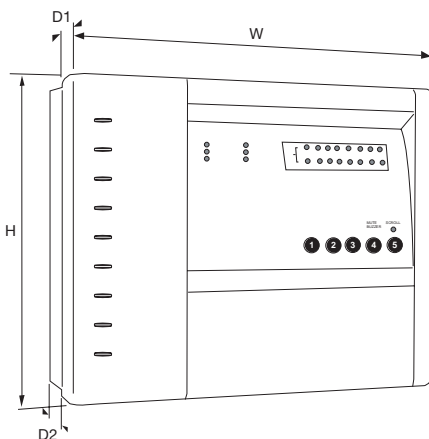

	H (mm)	W (mm)	D1 (mm)	D2 (mm)
2 / 4 zone panel	270	332	45	47
Cut-out	265	327	-	-

Note: If surface mounting add D1 and D2 to obtain depth dimension

Catalogue numbers

Description	Code
Conventional 2 Zone Panel	FX2202CPD
Conventional 4 Zone Panel	FX2204CPD
Conventional Repeater Panel	FXRP2200
Steel Back Box (for use with FX2202/4/8)	FX22003300 MB
Fire Alarm System Log Book	MFALOG

FXP5000 series

Conventional control panel



“Contemporary and compact panel design that provides a solution to any conventional system requirement”

The new FXP5000 conventional control panel is currently available in a 16 zone version. The panel features an array of user friendly features and are available at very competitive prices. The attractive flush or surface mountable plastic enclosure, with metal back box, has been designed through intensive voice of the customer research to provide ample space for termination of cables.

Benefits

- Zonal relay card as standard
- One man test facility
- Non latching zone feature
- Class change input
- Fire and fault relays
- Discreet enclosure
- Supplied complete with battery for 24 hour standby

FXP50016

No. of zones	16
Detectors per zone	30
No. of alarm circuits	4
Zonal relay card	✓



Dimensions

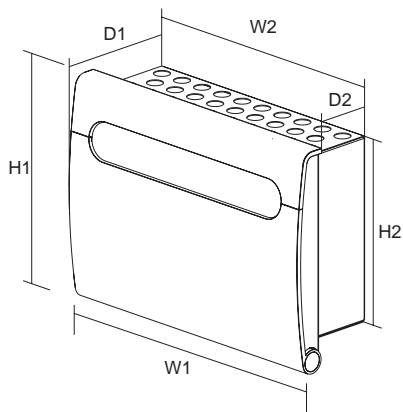

Description	H1 (mm)	W1 (mm)	D1 (mm)	H2 (mm)	W2 (mm)	D2 (mm)
	Total height	Total width	Total depth	Back box height	Back box width	Back box depth
16 Zone	276	375	136	232	335	96

Catalogue numbers

Description	Code
16 zone control panel	FXP50016
Fire alarm system log book	MFALOG

Conventional systems

Devices - detectors and remote indicator

Detectors and remote indicator

The conventional range offers a multi-mode, 5 in 1 detector (FXN922), covering many building needs. It's quick and simple to install with a stylish low profile design. The detector is mounted on our standard conventional base (FXN520) but can also be used in conjunction with our relay base (FXN520R) for local switching. Each detector is fitted with a 360° viewable LED for indication.

This multi-mode detector can be configured to operate as either an optical detector, photo-thermal detector or 1 of 3 heat detector modes (A1R, BS, CS) using the four position switches located at the back of the detector. The FXN922 is certified for use in all 5 modes.

Multimode detector FXN922



Base not included. See p72 for compatible bases.

Optical smoke detector mode

Typical applications:

Suitable for most applications.

Fastest response to slow burning or smouldering fires which give rise to large visible smoke particles.

Rate of rise heat detector mode

Typical applications:

Environments where the ambient conditions might cause false alarms with smoke detectors.

Examples include areas with high levels of dust or fumes.

Fixed heat detector (92°) mode

Typical applications:

Environments where the ambient heat levels are likely to be above normal temperatures, such as restaurant kitchens.

Photo-thermal detector mode

Typical applications:

Responds quickly to fast clean burning fires.

Maintains the advantage of optical sensors when detecting smouldering fires.

Fixed heat detector (77°) mode

Typical applications:

Environments where a change in temperature is a likely occurrence. Using a fixed heat negates false alarms from insignificant temperature rises.

Note:

We can also supply separate detectors for each individual mode if they are required. These are displayed in the catalogue numbers in the table over the page.

Remote indicator FX251D



Typical applications:

The remote indicator is ideal for applications such as void spaces or outside locked or inaccessible rooms to provide indication of the activation of an automatic detector.

Dimensions

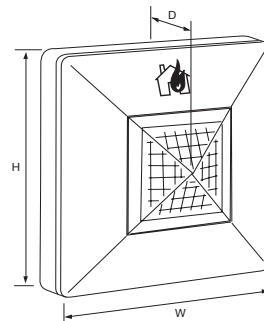

Description	H (mm)	W (mm)	D (mm)
Remote indicator	87	87	49

Performance

Feature	Optical smoke mode	Photo-thermal mode	Rate of rise mode	Fixed heat 77 °C mode	Fixed heat 92 °C mode
Area coverage (subject to local standards)	100m ²	100m ²	50m ²	50m ²	50m ²
Heat class	N/A	A2S	A1R	BS	CS
Alarm temperature	N/A	60 °C	60 °C	77 °C	92 °C

Dimensions

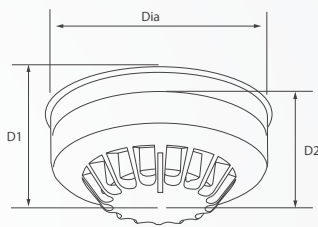

Description	Diameter (mm) (incl base)	Depth (mm) (incl base)	Depth (mm) (excl base)
Multimode detector*	104	42	55
Optical smoke detector	104	33	45

* All other conventional detectors share same dimensions

Switch settings

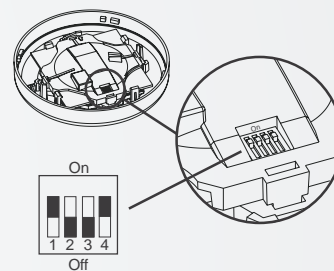

Description	SW1	SW2	SW3	SW4
Optical mode	-	OFF	OFF	OFF
Photo-thermal mode	-	OFF	OFF	ON
Rate of rise mode	-	ON	OFF	OFF
Fixed heat 77° mode	-	OFF	OFF	ON
Fixed heat 92° mode	-	ON	ON	OFF



Catalogue numbers

Description	Code
5 in 1 Multi-Mode Detector	FXN922
Optical Smoke Detector	FXN533
Photo-Thermal Detector	FXN632
Rate of Rise Heat detector	FXN525
Fixed Heat Detector 77 °C	FXN524
Fixed Heat Detector 92 °C	FXN526
Remote Indicator	FX251D
Weatherproof Remote Indicator	CIR301WP

Conventional systems

Devices - bases and beam detectors

Bases

There are two types of conventional detector bases, compatible with our range of detector heads to provide a wide functionality for different applications. The standard base (FXN520) is a general use product, providing a foundation for our conventional detectors, whereas the relay base (FXN520R) provides a local relay signal in the event of its host detector being triggered, making it ideal for instigating a local response.

Standard base FXN520



Typical applications:

General use product, suitable for use in most indoor applications.

Relay base FXN520R



Typical applications:

Areas where a local response is required.

Dimensions

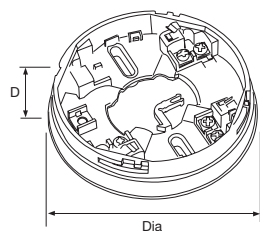

Standard base

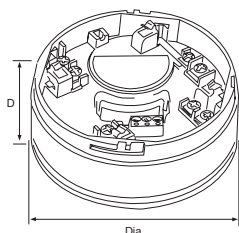

Relay base

Description	Dia (mm)	D (mm)
Standard base	104	22
Relay base	102	40

Beam detectors

There are two zone powered reflective beam detectors designed to be fully compatible with our conventional control panels. The MBD50R has a range of up to 50 meters and the MBD100R has a range of up to 100 metres. Neither require a power supply and both are equipped with a simple set up mode to enable easy and quick alignment during installation.

Conventional reflective beam detector MBD50R / MBD100R

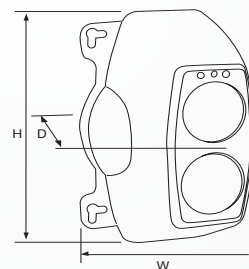
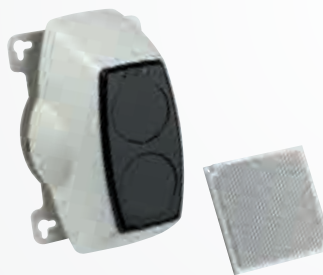

Typical applications:

Large open areas such as warehouses, manufacturing plants, shopping centres, airports etc.

H (mm)	W(mm)	D (mm)
210	130	120

Features

	MBD50R	MBD100R
Operating range	5 to 50 metres	50 to 100 metres
Tolerance to beam misalignment at 35%	Detector $\pm 0.8^\circ$, prism $\pm 5.0^\circ$	Detector $\pm 0.8^\circ$, prism $\pm 5.0^\circ$
Fire alarm thresholds	2.50dB (25%) 3.74dB (35%) 6.02dB (50%)	2.50dB (25%) 3.74dB (35%) 6.02dB (50%)
Optical wavelength	880nm	880nm

Beam detectors have 3 operating modes:

Prism targeting mode designed to provide simple initial alignment of beam and reflector assembly.

Alignment mode enables accurate fine tuning of beam alignment without the need for additional calibration equipment or a second operator.

Normal running mode during standard operation.

Duct probe detector

The presence of smoke in a ventilation duct is detected by sampling the airflow through the duct via two sampling tubes. An optical detector and base are mounted within the sampling chamber, which is located on the external skin of the duct, with sample and exhaust probes passing into the duct in an area of low turbulence.

Duct probe unit MDP201



Typical applications:

Detecting presence of smoke in ventilation ducts.

Duct probe unit shown with optical detector - detector and base must be ordered separately.

Features

Duct width range	300mm to 1500mm 5 to 50 metres
Duct air speed range	1m/s to 20m/s Detector $\pm 0.8^\circ$ Prism $\pm 5.0^\circ$
Temperature range	-20°C or +60°C

Catalogue numbers

Description	Code
Standard base	FXN520
Relay base	FXN520R
Reflective beam detector (50m range)	MBD50R
Reflective beam detector (100m range)	MBD100R
Mounting bracket	MRBFP
Duct probe unit	MDP201



Duct probe units can be used to detect the presence of smoke in a ventilation duct

Conventional systems

Devices - callpoints

Callpoints

Two versions of the conventional callpoint are available, the surface or flush mounted FX201 or the weatherproof FX203. Both have an integral short circuit isolator and are very simple to install. The callpoints are packaged with 2 frangible glass elements and test key, with a comprehensive range of further devices available.

Surface/flush mounted callpoint

FX201



Weatherproof callpoint

FX203



Dimensions

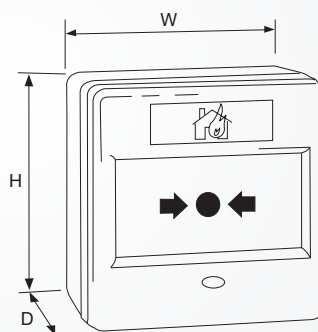

Typical applications:

General use product, suitable for use in most indoor applications.

Typical applications:

Builds requiring a callpoint in harsh conditions. For example, outside or in a wash down area.

Description	H (mm)	W (mm)	D (mm)
Surface mounted	87	87	57
Flush mounted	87	87	36
Weatherproof	87	87	59

Features

	FX201	FX203
Fast fit clip	✓	✓
Heavy duty terminals	✓	✓
Ingress protection	IP24D	IP65

Catalogue Numbers

Description	Code
Surface/flush callpoint	FX201
Weatherproof callpoint	FX203
CXPC Protective hinged cover (pack of 10)	4990001FUL0022
Spacer plates (pack of 10)	MBGSP
MBGBEZ Recessing bezels (pack of 10)	4990005FUL0194
MBGREKIT Resettable element kit (pack of 10)	4990010FUL0045
FX5G Spare break glasses (pack of 10)	516200FULL5017
Earth continuity links (pack of 5)	MBG119
MFBGKEY3 Callpoint keys (pack of 10)	4990009FUL0040

Further accessories:



Callpoint shown with protective hinged cover

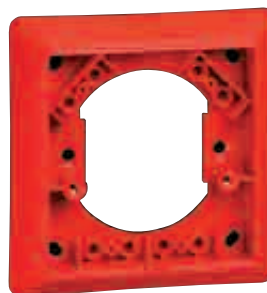

Callpoint recessing bezel

Bells

Bells still remain a popular choice for many applications where they can sometimes be used as a signal for non-fire purposes, such as class change in a school.

Internal 6 inch bell FX006



Typical applications:

Can be used for non-fire applications, such as class change in a school.



Dimensions

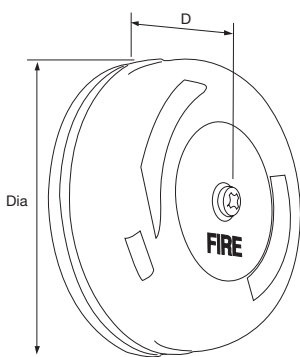

Internal 6 inch bell

Description	Dia (mm)	D (mm)
6 inch internal bell	152	63

Sound output

	FX006	MWB824
Sound Output	93-95dB(A) at 24V dc	95dB(A) (+/-2)

Catalogue numbers

Description	Code
FX006 Internal 6 inch bell	521601FULL-1601

Conventional systems

Devices - sounders

Sounders

We have an extensive range of conventional sounders, designed to meet every specification's functional and aesthetic needs. Completely EN54 Pt. 3 certified, each sounder offers a unique solution to your conventional system requirements.

Flush sounder FX003

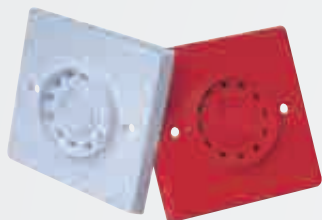

Typical applications:

Ideal for retail, hotel and residential applications such as sheltered housing.

Surface sounder FX002SB



Typical applications:

This all-purpose sounder has been designed to be both robust and aesthetically pleasing to meet many build requirements.

Weatherproof surface sounder FX002DB



Typical applications:

The weatherproof sounder is perfect for harsh weather conditions where a sounder is needed. With selectable tones a high volume can be easily achieved meaning this sounder functions well in outdoor settings.

High output wall sounder FX007



Typical applications:

With a maximum output of 120dB(a), this sounder is ideal for areas with high ambient noise levels like warehouses.

Low current wall sounder MLC624



Typical applications:

Designed to provide a high sound output with a low current consumption the MLC624 is perfect for areas where high sound levels need to be achieved but sounder circuit capacity is limited.

Base mountable sounder FXN824



Typical applications:

With a slim and aesthetically pleasing design this base sounder is ideal for applications such as hotel bedrooms where a detector/sounder or a detector/sounder-beacon is required.

Please note a detector base is still required when used in conjunction with a detector



Wall sounder detail

Sound output

	FX003	FX002	FX007	MLC624	FXN824
Sound output	98dB(a) at 1 Metre (+/-2)	105dB(a) max (+/-2) at 24V dc	120dB(a) (+/-2) Max at 1m (tone 5) 114dB(a) (+/-2) Max at 1m (tone3)	100dB(a) at 24V dc	80/90dB(a) (+/-3) @ 1 Metre
Tones	32	32	32	3	8

Dimensions

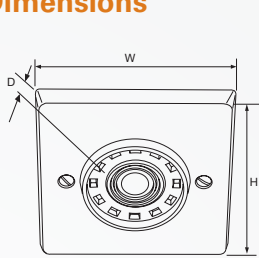

Flush sounder

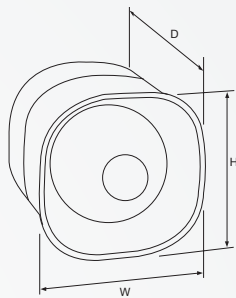

Wall sounder

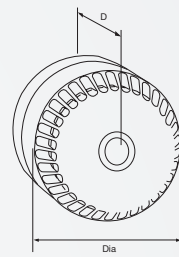

Surface sounder

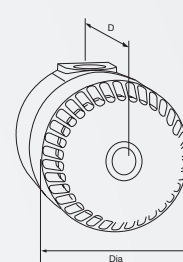

Weatherproof surface sounder

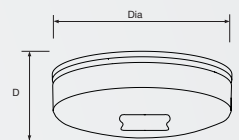

Base mountable sounder

Description	H (mm)	W (mm)	D (mm)
Flush sounder	86	86	36
High output wall sounder	105	105	95
Low current wall sounder	105	105	95

Description	Dia (mm)	D (mm)
Surface sounder	93	63
Weatherproof surface sounder	93	93
Base mountable sounder	111	26

Catalogue Numbers

Description	Code
FX003 Flush sounder, red	550001FULL-0001X
FX003W Flush sounder, white	550015FULL-0017X
MFSSBB Back box for FX003, red	591001FULL-0016
FX002SB Low profile surface sounder, red	540501FULL-0389X
FX002DB Weatherproof deep base surface sounder back box, red (IP65)	540503FULL-0403X
FX007 High output wall sounder	651004FULL-0009X
MLC624 Low current wall sounder	650001FULL-0003X
FXN824 Base mountable sounder	666058FULL-0098X
MDS824COV Blanking plate for FXN824 (pack of 5)	590037FULL-0305



Conventional systems

Devices - EN54-23 visual alarm devices

Visual alarm devices (VADs)

From 31st December 2013 a new beacon standard, EN 54-23 became mandatory throughout the EU where Construction Product Regulation (CPR) applies. It directly affects the use of visual alarm devices (VADs) in fire detection and alarm systems for non-domestic premises. Its purpose is to standardise the requirements, test methods and functional criteria of VADs to ensure that their visual performance is measured and presented in a uniform manner.

Eaton's LX range has been designed to comply with the new EN 54-23 standard. With current consumption as low as 10mA, the range has been developed to provide the lowest current consumption with the highest possible coverage. Three years in the making, the LX range, available for wall and ceiling applications, features a number of patented technologies including an innovative lens and flash pattern.

Solista LX wall FXSOLWRS



Typical applications:

With both a shallow base and deep base option the Solista meets requirements of a large range of builds.

Solista LX ceiling FXSOLCWS



Typical applications:

The ceiling option Solista helps to cover different types of room sizes to meet the requirements of the CoP 0001 design guidelines.

RoLP LX wall FXROLPWR



Typical applications:

The RoLP LX Wall is ideal for dual use applications where a visual alarm device is required in addition to an audible alarm.

The RoLP LX Wall is available to use with any standard RoLP sounder.

Symphoni LX wall FXSYG1WR



Typical applications:

The Symphoni LX Wall base can be used in combination with any standard Symphoni sounder.

Its high sound output makes it suitable for open areas or areas where there is higher than normal background noise.

Symphoni LX WP wall (weatherproof) FXSYG1WR-WP



Typical applications:

The Symphoni LX WP Wall device offers a weatherproof alternative to the Symphoni LX Wall device. With an ingress protection rating of IP66, it is suited for wet and outdoor environments.

These products are all **red flash**, for more options please contact:

techsupport@cooperfire.com

Performance

	Solista LX wall	Solista LX ceiling	RoLP LX wall	Symphoni LX wall	Symphoni LX WP wall
Sound output	N/A	N/A	102dB(A) (Typical tone 3 - RoLP)	100dB(A) (Typical tone 3 - Symphoni)	100dB(A) (Typical tone 3 - Symphoni)
Minimum current consumption	10mA	10mA	22mA	15mA	15mA
EN54-23 coverage reference	W-2.4-7.5	C-3-7.5	W-2.4-7.5	W-2.4-7.5	W-2.4-7.5
Coverage volume	135m ³ (15m ³)	132m ³ (21m ³)	135m ³ (15m ³)	135m ³ (15m ³)	135m ³ (15m ³)
Flash rate	1Hz (switchable to 0.5Hz)	1Hz (switchable to 0.5Hz)	1Hz (switchable to 0.5Hz)	1Hz (switchable to 0.5Hz)	1Hz (switchable to 0.5Hz)

Dimensions

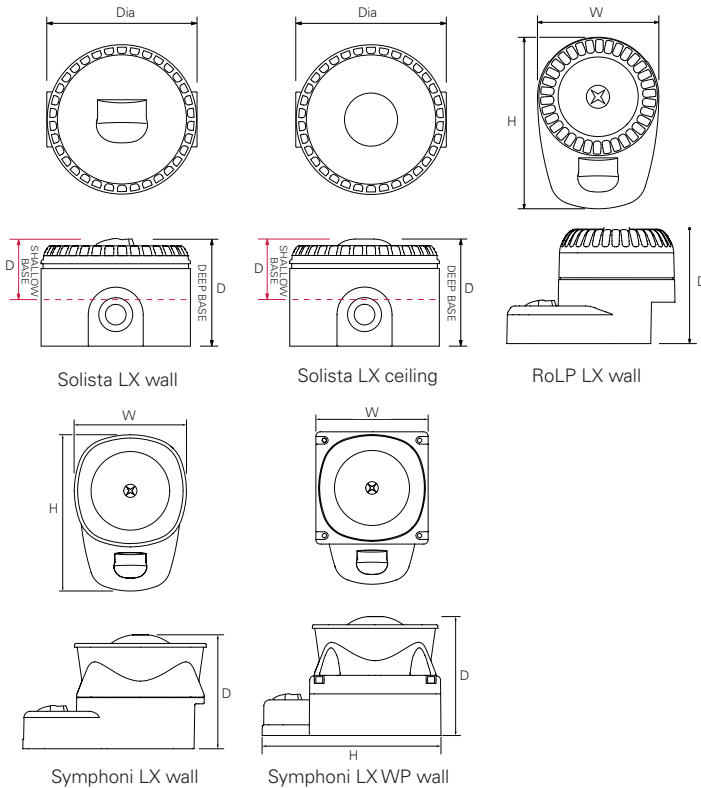

Description	Dia (mm)	D (mm)	W (mm)	H (mm)
Solista LX wall deep base	93	66	-	-
Solista LX wall shallow base	93	38	-	-
Solista LX ceiling shallow base	93	37	-	-
RoLP LX wall	-	95	95	135
Symphoni LX wall	-	92	106	147
Symphoni LX WP wall	-	92	106	147

Catalogue numbers

Description	Code
FXSOLWRS Solista wall red body shallow base	812013FULL0237X
FXSOLWRD Solista wall red body deep base	812005FULL0107X
FXSOLCWS Solista LX ceiling	812022FULL0123X
FXROLPWR RoLP wall red body base and sounder	8500025FULL0025X
FXROLPWR-B RoLP wall red body base only	8500040FULL0219X
FXSYG1WR Symphoni LX wall red body	8500045FULL0233X
FXSYR-B Symphoni LX wall base red body	8500095FULL0231X
FXSYG1WR-WP Symphoni LX wall weatherproof red body	8500050FULL0249X
FXSYR-B-WP Symphoni LX wall weatherproof base red body	8500100FULL0247X



For more guidance on EN-54-23 and placement of VADs, refer to our Fire Installer's Mate pocket guide.

(Part code CFS-CC2478-FIM)



Conventional systems

Devices - indicators

Indicators

In areas which do not have to meet the new regulations regarding EN54-23 visual alarm devices, our range of indicators can still provide reliable light indication.

Low profile LED indicator MLB124SB



Weatherproof LED indicator MLB124DB



Typical applications:

In regions where the EN54-23 VADs standard is not a requirement, the LED indicator can be used as an indicating device.

Typical applications:

The weatherproof version of the LED indicator provides an IP65 option ideal for outdoor use.



Dimensions

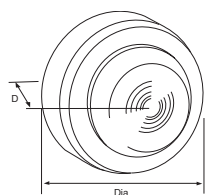

Low profile LED indicator

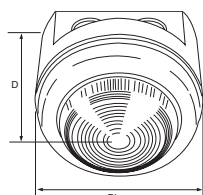

Weatherproof LED indicator

Description	W (mm)	D (mm)
Low profile LED indicator	95	53
Weatherproof LED indicator	95	80

Note: From 31st December 2013 a new beacon standard, EN 54-23 became mandatory across Europe where Construction Product Regulation (CPR) applies. If you are in a region where this standard applies please understand that these indicators do not meet the requirements of the new standards - **see p78 for compliant beacons and sounder beacons**

Catalogue numbers

Description	Code
MLB124SB Low profile LED beacon	811012FULL-0006
MLB124DB Weatherproof LED beacon	811013FULL-0007

Sounder indicators

In areas which do not have to meet the new regulations regarding EN54-23 visual alarm devices, our range of sounder indicators can still provide excellent sound quality and light indication.

Xenon sounder indicator FL-RL-R-S



Typical applications:

In regions where the EN54-23 VADs standard is not a requirement, the xenon sounder indicator provides an alternative option to the xenon indicator - where an audible warning is required in addition to light indication.

Weatherproof Xenon sounder indicator FL-RL-R-D



Typical applications:

The weatherproof version of the sounder indicator is IP65 rated which allows for installation in harsher environments.

Dimensions

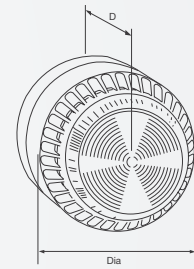

Xenon sounder indicator

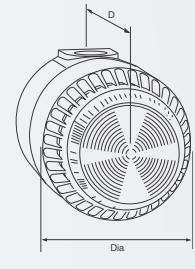

Weatherproof xenon sounder indicator

Description	Dia (mm)	D (mm)
Xenon sounder indicator	93	92
Weatherproof xenon sounder indicator	93	121

Sound output

XENON sounder indicator, FL-RL-R-S/FL-RL-R-D

Sound output	101dB(a) at 24V dc (typical tone 3)
Tones	32

Note: From 31st December 2013 a new beacon standard, EN 54-23 became mandatory across Europe where Construction Product Regulation (CPR) applies. If you are in a region where this standard applies please understand that these indicators do not meet the requirements of the new standards - **see p78 for compliant beacons and sounder beacons**

Catalogue numbers

Description	Code
FL-RL-R-S Conventional xenon sounder indicator	640001FULL0003X
FL-RL-R-D Weatherproof IP65 xenon sounder indicator	640031FULL0111X

Conventional systems

Devices - door retainers and relay unit

Door retainers and relay unit

Door retainers enable doors to be held open under normal conditions but automatically be released in the event of fire alarm activation.

Eaton have a range of door retainers which are robust and simple to install. Both floor and wall mounted retainers, with either mains or 24V dc power supplied variations, are available.

Heavy duty door retainer MDR240/MDR24L



Compact door retainer FX021240LC/ FX02124VLC



Heavy duty relay unit MAR724



Typical applications:

Robust and simple to install, the heavy duty door retainer is ideal for a wide range of applications, such as nursing homes, hospitals, schools and industrial premises.

Typical applications:

Equally as reliable, the compact door retainer is also a good choice for nursing homes, hospitals and also busy corridors.

Typical applications:

Designed for interfacing heavy loads such as door release units or plant shut down equipment with fire alarm systems.

This unit is simple to fix and install and the neat unobtrusive design makes it suitable for use in a wide range of areas.

The heavy duty relay unit is powered by 24V dc external supply and is provided with 2 separate sets of changeover contacts.

Can switch 230V ac mains at 10A

Performance

	MDR240	MDR24L	FX021240LC	FX02124VLC
Holding force	40kg	40kg	45kg	40kg
Power consumption	1.2VA	40mA	1.2VA	40mA

Catalogue numbers

Description	Code
Mains powered heavy duty door retainer	MDR240
24V dc heavy duty door retainer	MDR24L
Floor mounting bracket for heavy duty door retainers	ZMDRFBB
Mains powered compact door retainer	FX021240LC
24V dc compact door retainer	FX02124VLC
Floor mounting bracket for compact door retainers	FX021LCFB
Spare striker plate for either magnet	ZMDRSWIV
Heavy duty relay unit	MAR724

Power supply

Specifically recommended as an auxiliary power supply unit for fire detection system components such as electromagnets, notification devices, etc.

Using the unit in large systems eliminates the problem of long power cable runs which simplifies installation.

EN54 pt.4 approved power supply unit SPS Range



Typical applications:

The new range of EN 54-4 certified safety power supplies offer a compact, robust and versatile power solution to installers, allowing them to safely power fire detection and signaling systems in small to large installations.

Compact and discrete design allows for these SPS to be installed in a visible location such as a hotel lobby for instance. Comprehensive yet simple status indicators on the front of the unit help installers, commissioners and maintainers assess status of the unit.

Catalogue numbers

Description	Code
Safety power supply 24V / 1.5A (batteries not supplied)	SPS-2423
Safety power supply 24V / 2.5A (batteries not supplied)	SPS-2433
Safety power supply 24V / 4.5A (batteries not supplied)	SPS-2453



Door retainers enable doors to be held open under normal conditions but automatically be released in the event of fire alarm activation.



Contents

Emergency voice communications

Panels

Network exchange units **86**



Non network exchange units **88**



Devices

Outstations **90**



Emergency assist alarm **92**



Network exchange units

Our range of EVCS control units cover functionality for all builds, whether small and basic or larger and more complex. All parts are designed to fully comply with BS5839 part 9 2011 with EN54-4-A2 compliant power supplies and chargers.

Network master handset CFVCWM



Features

Up to 8 network master handsets per system	✓
Controls up to 128 lines (16 x 8 line exchange units)	✓
Monitored handset	✓
Large high contrast display (4 x 20 character)	✓
Dual network ports	✓
Remote powered handsets, no mains required	✓
Full system event log (fault & configuration)	✓

Dimensions

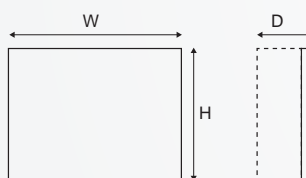

Description	H (mm)	W (mm)	D (mm)
VoCALL Network Master Handset	300	300	65

*Please check with our technical team if dimensions are critical as they may have changed from time of print

Each system can have up to 8 VoCALL Network Master Handsets which gives great flexibility to larger installations allowing all calls to be monitored from various control points. As an example, an installation may have security offices, reception and numerous entrances that need to be monitored by master handsets.

- Wall or desk mount
- Graphical display
- Calls can be made by dialling or selecting the outstation name

8 line network exchange unit CFVCX8



The VoCALL Network 8 Line Exchange Unit is a small wall mounted unit which can be distributed throughout a site and concealed from view in convenient locations such as risers, stairwells and cupboards.

- Greatly reduces cabling requirement
- Less equipment 'on view' in key places such as reception areas
- Aesthetically pleasing system with minimal equipment

Up to 8 lines can be connected to each distributed exchange, and each cable is fully monitored for open, short or earth faults. Up to 168 outstation Exchange Units can be attached to a VoCALL Network master system giving a maximum system size of 128 independent lines.

**VoCALL Compact 9 Line Master
and 10 Line Slave Exchange Unit
CFVCCM9* / CFVCCS10***



*See website for further details



Catalogue numbers

Description	Code
VoCALL 8 line network master handset	CFVCWM
VoCALL 8 line network exchange unit	CFVCX8
VoCALL Compact 9 Line Master Unit	CFVCCM9
VoCALL 10 Line Slave Exchange Unit	CFVCCS10

Emergency voice communications

Master exchange units (non networkable)

Standalone master exchange units (non networkable)

Our range of EVCS control units cover functionality for all builds, whether small and basic or larger and more complex. All units are fully certified to EN54-4:A2 with compliant power supplies and chargers. The EFVCC5 and EFVCM10 are our non-networkable standalone options for small and medium sized builds.

VoCALL Compact 5

EFVCC5



Typical applications:

The VoCALL Compact 5 Line Unit is ideal for smaller installations which require just a limited number of outstations and Emergency Assist Alarms.

The EFVCC5 is a standalone unit containing the systems master handset, EN54-4 approved power supply and connectivity for the 5 outstations. 20mm knockouts are provided for all system cabling and the housing is of ample size to support 2x 3.2Ah backup batteries.

Features

Compact 5

Bs5839 pt9 2011 compliant	✓
Monitored handset	✓
Monitored supply and charger	✓
Relay outputs	✓
No programming	✓
Functional with emergency assist alarms	✓

Dimensions

Dimensions	H1 (mm)	H2 (mm)	W1 (mm)	W2 (mm)	D1 (mm)	D2 (mm)
VoCALL Compact 5 surface mounted	280	-	397	-	77	-
VoCALL Compact 5 flush mounted	280	309	397	427	77	16

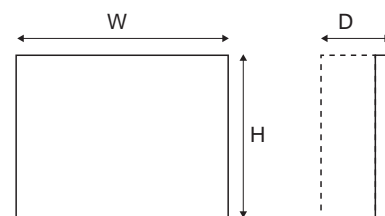



Catalogue numbers

Description	Code
VoCALL compact 5 line master exchange unit, non-network, surface mount, graphite	EFVCC5
VoCALL compact 5 line master exchange unit, non-network, flush mount, stainless steel	EFVCC5SS

Outstations

For disabled refuge systems we offer a number of devices for call functions. Outstations can offer functionality as a fire telephone or disabled refuge call point. All outstations are available as a wall mountable unit, or with an optional bezel to allow the product to be flush mounted.

Type A outstation CFVCSHP



Type B outstation CFVCSHF



Combined Type A & B outstation CFVCDUO



Roaming handset and jack plate CFVCRJP/CFVCRHS



Typical applications:

All builds which require a disabled refuge EVC system.

The Type A should be used for evacuation or firefighting use.

Note:

There is a weatherproof, IP65 rated version of the Type A outstation available with a lockable door. Please enquire for more information.

Typical applications:

Type B outstations can only be used where the background noise is below 40dBA (therefore there can be no sounder or voice alarm coverage in the area).

Typical applications:

For situations where both a fire telephone and a disabled refuge point are required in the same location.

In normal use the Type B Green disabled refuge point operates and rings, however if the door is opened and the Fire telephone handset is lifted, a call from the handset is directed to the control point instead.

Typical applications:

When used together, the roaming handset and jack plate form a Type A outstation. This can be used in countries whose fire codes allow for roaming handsets.

(These units are not suitable for installation in the UK under BS5839 Pt9.)

Dimensions

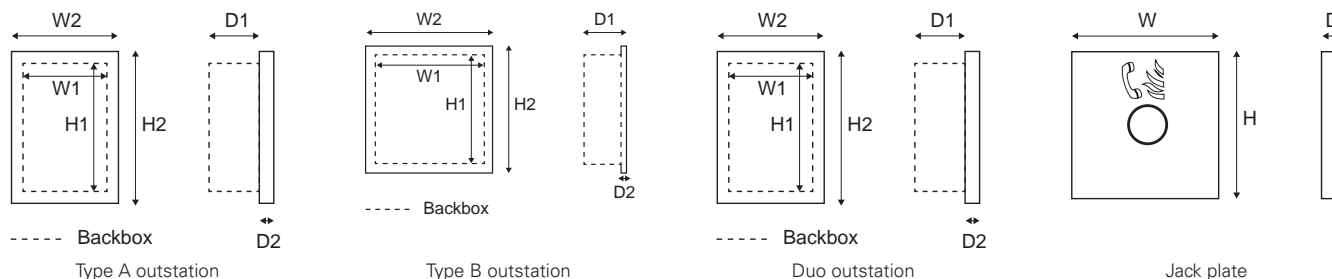

Description	H1 (mm)	H2 (mm)	W1 (mm)	W2 (mm)	D1 (mm)	D2 (mm)
Type A outstation backbox	320	-	152	-	85	-
Type A outstation flush mounted	320	334	152	191	85	2
Type B outstation backbox	135	-	135	-	45	-
Type B outstation flush mounted	135	154	135	154	45	2
Duo outstation backbox	480	-	190	-	82	-
Duo outstation flush mounted	480	494	190	204	82	2
Jack plate	86	-	86	-	25	-



Catalogue numbers

Description	Code	Description	Code
VoCALL Type A outstation, surface mount, red	CFVCSHP	VoCALL Type B outstation, surface mount, red	CFVCSHF
VoCALL Type A outstation, surface mount, stainless steel	CFVCSHPSS	VoCALL Type B outstation, surface mount, green	CFVCSHFG
VoCALL Type A outstation, flush mount, red	CFVCFHP	VoCALL Type B outstation, surface mount, stainless steel	CFVCSHFSS
VoCALL Type A outstation, flush mount stainless	CFVCFHPSS	VoCALL flush mounting bezel for use with any Type B outstation, stainless steel	CFVCFHB
VoCALL Type A uncased red handset	CFVCHFS	VoCALL combined Type A and Type B flush mount outstation	CFVCDUO
VoCALL Type A outstation, IP65 lockable, surface mount, red	CFVCIPA	VoCALL jack plate	CFVCRJP
		VoCALL roaming handset	CFVCRHS

Emergency assist alarm equipment

Emergency assist alarms are required by building regulation document M.

We offer either a stand-alone kit or a kit which integrates the Emergency Assist equipment with our VoCALL products.



Our emergency assist alarm kits supply everything you need to install a fully compliant system.

VoCALL kit

This Emergency Assist Alarm - VoCALL kit has been specifically designed to integrate disabled call functions into the VoCALL network or VoCALL compact ranges.

It is fully monitored and battery backed by the VoCALL system. The Emergency Assist Alarm shows up as a call on the VoCALL system, but has no speech path so a conversation cannot be had with the occupant, use of the Type B Outstations would allow this.

Stand alone kit

The Emergency Assist Alarm - stand alone kit provides the perfect solution for conformity with the Building Regulations Document M and Equality Act 2010.

The Emergency Assist Alarm - stand alone kit comprises of all the components needed to install a fully compliant system, with additional parts available separately.

4 way splitter

The 4 Way Splitter Unit allows up to 4 stand alone disabled toilets to be monitored in one specific area. Staff can then, at the designated area such as a reception or security desk, react to an alarm swiftly and efficiently.

EAA VoCALL kit CFVCEA



Typical applications:

Disabled Toilets.

Includes:

- Over door indicator
- Cancel button
- Pull cord unit
- Disabled sticker pack

Does not include PSU as the kit is powered by a master unit (the Compact 5, see p88)

Accessories:



Pull cord unit

EAA standalone kit CFEAPULLKIT



Typical applications:

Disabled Toilets.

Includes:

- Power supply unit
- Over door indicator
- Cancel button
- Pull cord unit
- Disabled sticker pack



4 way splitter

Catalogue numbers

Description	Code
Emergency assist alarm - vocall kit	CFVCEA
Emergency assist alarm - stand alone kit	CFEAPULLKIT
4 way splitter	CFEASL4
Pull cord unit	CFEAPULL



Emergency assist alarm stand alone kit, basic usage schematic



Contents

Voice alarm system

Panels

Distributed amplifier unit **96**



Emergency mic all call **96**



Devices

Speakers **98**



Voice alarm system

EESDAU100 - voice distributed amplifier unit

VoCALL emergency evacuation systems

The VoCALL Voice series of public address and voice alarm systems are scalable, so can be used in any sized installation.

Voice distributed amplifier unit (DAU) EESDAU100



NEW
PRODUCT

The Emergency Evacuation System Distributed Amplifier Unit (DAU) is a complete VA system, which has been developed to replace talking sounders in many voice alarm applications.

It is supplied in a single wall mount box which is complete with messages, contacts, dual 50W monitored amplifiers, EN54-4 approved power supply, monitored battery charger and the ability to connect non-monitored paging and music sources directly.

The boxes can be connected together using the network ports so a system with up-to 128 nodes is achievable. The system can be paged from the All Call EESEMA fire microphones.

- Can function as a stand alone or networked system
- EN54-16 and EN54-4 LPCB certified for CPR
- BS5839 part 8, 2008 compliant
- Dual 50W 100V line outputs
- 3 Messages 130 second total
- Wall mounted
- Common fault out
- Paging input
- Full fault monitoring
- EN54-4 battery charging and monitoring
- Direct music input
- Music ramping
- Up to 128 units per network

Emergency microphone all call (EMA) EESEMA



NEW
PRODUCT

The Emergency Evacuation System Emergency Microphone All Call (EMA) is designed to provide an All Call emergency microphone as the top priority of the network.

All connections are fully monitored for open, short and earth faults and the microphone capsule is also monitored for open and short conditions.

The pre-amplifier is a high quality compressor limiter, which prevents the system from being overdriven by poor microphone use, it also corrects for quiet speakers. Tone controls allow the microphone to be equalised for maximum clarity and the chime is selectable (1,2 or 3 note) and volume controlled independently of the voice level.

- EN54-16 CPR certified by LPCB
- Fully monitored
- Close coupled noise cancelling fist microphone
- Studio quality compressor limiter
- Wall mounted enclosure
- Bass and treble controls
- Selectable message chime
- Secure controls inside panel
- Three message trigger buttons and cancel button
- Compliant high visibility signage
- BS5839 part 8, 2008 compliant
- Network powered



Dimensions

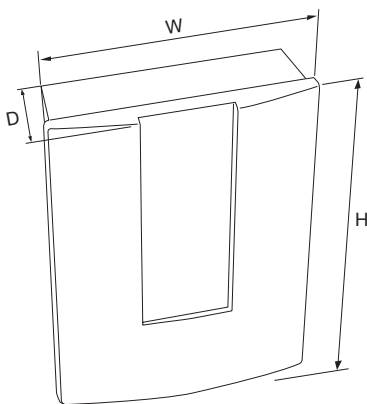

	H (mm)	W (mm)	D (mm)
Voice DAU panel	400	320	180
EMA panel	400	320	180

Catalogue numbers

Description	Code
100W addressable DAU	EESDAU100
Emergency microphone all call	EESEMA

Speakers

Whether the call is for discreet ceiling speakers in a hotel or for vandal resistant weatherproof columns on a station, there is a suitable model within the range to match the most demanding environments. Where the speakers are required to operate in a highly secure life safety Voice Alarm system then versions are available which are fire rated and have been designed to fully comply with BS5839-Pt8 and EN54-24.

Vandal resistant loudspeaker SENTRY6ST/ENC



Typical applications:

Recommended for voice evacuation systems, these units are ideally suited for use in shopping centres, prisons, schools, railway stations etc.

Sound projector CAD10T/ENC



Typical applications:

With rugged construction, these units are ideally suited for use in corridors, passageways, shopping centres, prisons, car parks, railway stations and other public places.

The CAD10T/ENC projector speaker has a fitted U-bracket.

Weatherproof horn APH10T/ENC



Typical applications:

Designed for installation in outdoor or ambient temperature areas where a wide angle of coverage is required, these weatherproof horns are a practical solution for car parks, courtyards and warehouses.

Ceiling loudspeaker MC range



Typical applications:

Ideal for general public address, background music and voice evacuation systems.

These 10W speakers come in sizes from 5" to 6" in diameter, designated by the part codes MC5-EN and MC6-EN.

Performance

Feature	SENTRY6ST/ENC	CADIOT/ENC	APHIOT/ENC	MC5-EN	MC6-EN
Output	100dB at 10W	104dB at 20W	101db at 20W	103dB at 10W	103dB at 10W
Sensitivity	90dB at 1W	92dB at 1W	88dB at 1W	93dB at 1W	93dB at 1W
IP rating	IP66	IP54	IP65	NA	N/A

Catalogue numbers

Description	Code
Vandal resistant loudspeaker	SENTRY6ST/ENC
Projector speaker	CAD10T/ENC
Weatherproof horn	APH10T/ENC
5" ceiling loudspeaker	MC5-EN
6" ceiling loudspeaker	MC6-EN



Product code cross reference

Page No.	Description	Cooper Code	Menvier Code	JSB Code
Addressable				
P18	2 Loop Control Panel	CF2000GCPD	DF2000GCPD	FX2000GCPD
P19	Passive Repeater Panel	CF3000PRG	DF6000PRG	FX6000PR
P19	Fire Alarm System Log Book	MFALOG	MFALOG	MFALOG
P20	1 Loop Control Panel	CF1100VDS	DF6100VDS	FX6100VDS
P20	2 Loop Control Panel	CF1200VDS	DF61002VDS	FX61002VDS
P21	Add to end of product code if network card required	NC	NC	NC
P21	Network kit (for retro fit)	DF61NETKIT	DF61NETKIT	DF61NETKIT
P21	Passive Repeater Panel	CF3000PRG	DF6000PR	FX6000PR
P21	Touch-Screen Repeater Panel	CTPR3000	DTPR6000	DTPR6000
P21	Fire routing equipment PCB	ZPCB2187FRE	ZPCB2187FRE	ZPCB2187FRE
P21	Fire Alarm System Log Book	MFALOG	MFALOG	MFALOG
P22	2 Loop Control Panel	CF30002G	DF60002	FX60002
P22	2 Loop Control Panel, Integral Printer	CF30002GP	DF60002P	FX60002P
P22	2 Loop Control Panel, Extended Battery	CF30002GEB	DF60002EB	DF60002EB
P22	2 Loop Control Panel, Integral Printer, Extended Battery	CF30002GPEB	DF60002PEB	DF60002PEB
P22	4 Loop Control Panel	CF30004G	DF60004	FX60004
P22	4 Loop Control Panel, Integral Printer	CF30004GP	DF60004P	FX60004-P
P22	4 Loop Control Panel, Extended Battery	CF30004GEB	DF60004EB	DF60004EB
P22	4 Loop Control Panel, Integral Printer, Extended Battery	CF30004GPEB	DF60004PEB	DF60004PEB
P23	Add to end of product code if network card required	NC	NC	NC
P23	Touch-Screen Repeater Panel	CTPR3000	DTPR6000	DTPR6000
P23	Hinged Protective Cover Kit	CF3000COV	DF6000COV	DF6000COV
P23	Network kit (for retro fit)	DF6000NETKIT	DF6000NETKIT	DF6000NETKIT
P23	Printer kit (for retro fit)	CF3000PKIT	DF6000PKIT	DF6000PKIT
P24	Optical Smoke Sensor	400002FIRE-0002X	400002FIRE-0008X	400002FIRE-0005X
P24	Photo-Thermal Sensor	400004FIRE-0004X	400004FIRE-0010X	400004FIRE-0007X
P24	Heat Sensor	400003FIRE-0003X	400003FIRE-0009X	400003FIRE-0006X
P25	Loop connected remote indicator	MRIAD	MRIAD	MRIAD
P25	Standard remote indicator	CIR301	FX251D	FX251D
P25	Weather resistant standard remote indicator	CIR301WP	CIR301WP	CIR301WP
P25	CAB382 Staff warning device	666028FULL-0066	666028FULL-0066	666028FULL-0066
P26	Standard base	CAB300	MAB800	FXN720
P26	Sounder base	CAS380	MAS850	FXN538
P26	VAD Sounder beacon base	CASBB394	CASBB394	CASBB394
P26	Sounder beacon base	CASBB384	CASBB384	CASBB384
P26	Cover plate	CASC	CASC	CASC
P26	Bell tone sounder base	CAS380B	CAS380B	CAS380B
P26	Australian sounder base (Only for Australian Market)	CAS380AU	CAS380AU	CAS380AU
P26	Addressable relay base	MAB800R	MAB800R	MAB800R

Product code cross reference

Page No.	Description	Cooper Code	Menvier Code	JSB Code
P26	Base shroud	BAR3000	BAR3000	BAR3000
P28	Surface/Flush Callpoint	CBG370S	MBG813	FXN501
P28	Weatherproof Callpoint	CBG370WP	MBG817	FXN503
P28	CXPC Protective Hinged Cover (pack of 10)	4990001FUL-0022	4990001FUL-0022	4990001FUL-0022
P28	Spacer Plates (pack of 10)	MBGSP	MBGSP	MBGSP
P28	MBGBEZ Recessing Bezels (pack of 10)	4990005FUL-0194	4990005FUL-0194	4990005FUL-0194
P28	MBGREKIT Resettable Element Kit (pack of 10)	4990010FUL-0045	4990010FUL-0045	4990010FUL-0045
P28	UBSG Spare Break Glasses (pack of 5)	516200FULL-5017	516200FULL-5017	516200FULL-5017
P28	MFBGKEY3 Callpoint Keys (pack of 10)	4990009FUL-0040	4990009FUL-0040	4990009FUL-0040
P29	Internal Wall Sounder	CAS381	MAS850LPS	FXN538LPS
P29	Weatherproof Wall Sounder	CAS381WP	MAS850LPSPWP	FXN538LPSPWP
P29	Weatherproof wall sounder beacon	CASB383WP	CASB383WP	MASB383WP
P29	Wall sounder beacon	CASB383	CASB383	MASB383
P29	VAD Wall Sounder Beacon	CASB393	FXN559LPS	MASB880
P29	Weatherproof VAD Wall Sounder Beacon	CASB393WP	FXN559LPSPWP	MASB880WP
P29	Internal wall sounder bell tone	CAS381B	CAS381B	CAS381B
P29	Weatherproof wall sounder bell tone	CAS381WPB	CAS381WPB	CAS381WPB
P29	Australian internal wall sounder	CAS381AU	CAS381AU	CAS381AU
P29	Australian weatherproof wall sounder	CAS381WPAU	CAS381WPAU	CAS381WPAU
P29	VAD wall sounder beacon bell tone	CASB393B	CASB393B	CASB393B
P29	Weatherproof VAD wall sounder beacon bell tone	CASB393WPB	CASB393WPB	CASB393WPB
P31	Reflective Beam Detector (50m range)	MAB50R	MAB50R	MAB50R
P31	Reflective Beam Detector (100m range)	MAB100R	MAB100R	MAB100R
P31	Mounting Bracket	MRBFP	MRBFP	MRBFP
P31	Spare reflector	MABR	MABR	MABR
P31	Duct Probe Unit	MDP201	MDP201	MDP201
P32	Zone Monitor Unit	CZMU352	MIU871	FXN512
P32	Shop Monitor Unit	MSU840	MSU840	FXN516
P32	Spur Isolator Unit	CSI350	MSI850	FXN513
P32	3 Channel Input/Output Unit Resets on reset (recognised as 1 address)	CIO351	MIO324	FXN510
P32	3 Channel Input/Output Unit Resets on reset (recognised as 3 addresses)	CIO351T	MIO324T	FXN510T
P32	3 Channel Input/Output Unit Rests on silence alarms	CIO351S	MIO324S	FXN510S
P33	230V ac Relay Unit	CMIO353	MIO1240	FXN511
P34	4 way sounder controller unit	CSC354CPR	CSC354CPR	CSC354CPR
P34	Technical Input / Output Module	CFC301	CFC301	CFC301
P34	4 Way Mimic Relay Board, 4 Inputs, 4 Outputs	CIOP4	CIOP4	CIOP4
P34	8 Way Mimic Relay Board, 8 Inputs, 8 Outputs	CIOP8	CIOP8	CIOP8
P34	4 to 20mA Interface	CGI420	CGI420	CGI420
P35	Micro Zone Monitor Unit	MIU872	MIU872	MIU872

Product code cross reference

Page No.	Description	Cooper Code	Menvier Code	JSB Code
P35	Micro Single Channel Output Unit (recognised as output unit)	400010FIRE-0024X	400010FIRE-0024X	400010FIRE-0024X
P35	Micro Single Channel Output Unit (recognised as sounder)	400012FIRE-0026X	400012FIRE-0026X	400012FIRE-0026X
P35	Micro Single Channel Output Unit (5 second reset pulse)	400011FIRE-0025X	400011FIRE-0025X	400011FIRE-0025X
P35	Micro Single Channel Input Unit	400008FIRE-0022X	400008FIRE-0022X	400008FIRE-0022X
P35	Mini module box unit (empty box)	ULBU	ULBU	ULBU
P36	Dual-channel LonWorks BMS Interface (non handshake)	EC200	EC200	EC200
P36	Dual-channel LonWorks BMS Interface (handshaking)	EC200H	EC200H	EC200H
P36	Dual-channel LonWorks BMS Interface (self configuring for use with EC700)	EC200S	EC200S	EC200S
P36	Lon to RS232 Adapter	EC0232	EC0232	EC0232
P36	Lon to RS232 Adapter (for HMX PA/VA system - no handshake)	EC0232PAVA	EC0232PAVA	EC0232PAVA
P36	Lon to RS232 Adapter (for HMX PA/VA system - 3 min time delay)	EC0232PAVA3D	EC0232PAVA3D	EC0232PAVA3D
P36	TCP/IP Interface	EC400	EC400	EC400
P36	Lon Network Booster	EC540	EC540	EC540
P37	BACnet Gateway	EC650B	EC650B	EC650B
P37	Modbus Gateway	EC700	EC700	EC700
P37	Single Mode Lon to Fibre Optic Adaptor	CFSFL01	CFSFL01	CFSFL01
P37	Dual Channel Lon to Fibre Optic Adaptor	CFSFL02	CFSFL02	CFSFL02
P38	Loop Splitter Unit	ZPCB2222	ZPCB2222	ZPCB2222
P38	Mimic PCB (master)	ZPCB2252-MML	ZPCB2252-MML	ZPCB2252-MML
P38	Mimic PCB (slave)	ZPCB2252-MSL	ZPCB2252-MSL	ZPCB2252-MSL
P38	Safety Power Supply 24V / 1.5A (batteries not supplied)	SPS-2423	SPS-2423	SPS-2423
P38	Safety Power Supply 24V / 2.5A (batteries not supplied)	SPS-2433	SPS-2433	SPS-2433
P38	Safety Power Supply 24V / 4.5A (batteries not supplied)	SPS-2453	SPS-2453	SPS-2453
P40	Graph pack software (lite)	GRAPHPACK1-2LITE	GRAPHPACK1-2LITE	GRAPHPACK1-2LITE
P40	Graph pack software (1 panel)	GRAPHPACK1	GRAPHPACK1	GRAPHPACK1
P40	Graph pack software (2-5 panels)	GRAPHPACK2-5	GRAPHPACK2-5	GRAPHPACK2-5
P40	Graph pack software (6-10 panels)	GRAPHPACK6-10	GRAPHPACK6-10	GRAPHPACK6-10
P40	Graph pack software (11-20 panels)	GRAPHPACK11-20	GRAPHPACK11-20	GRAPHPACK11-20
P40	Graph pack software (21-99 panels)	GRAPHPACK21-99	GRAPHPACK21-99	GRAPHPACK21-99
P40	Graphh pack software (21-127 panels)	GRAPHPACK21-127	GRAPHPACK21-127	GRAPHPACK21-127
P40	Graph pack and site monitor	GRAPHSITEMON	GRAPHSITEMON	GRAPHSITEMON
P40	Site monitor / webserver software	SITEMONITOR	SITEMONITOR	SITEMONITOR
P41	Loop Tester Kit	LP800KIT	LP800KIT	LP800KIT
P41	Addressable Device Programmer	CF800PROG	CF800PROG	CF800PROG
P41	USB panel interface	USBINT2	USBINT2	USBINT2
UL Approved				
P44	2 Loop Panel	ULCF30002G	ULDF60002G	ULFX60002G
P44	2 Loop Panel, Integral Printer	ULCF30002GP	ULDF60002GP	ULFX60002GP

Product code cross reference

Page No.	Description	Cooper Code	Menvier Code	JSB Code
P44	2 Loop Panel, Network Card	ULCF30002GNC	ULDF60002GNC	ULFX60002GNC
P44	2 Loop Panel, Red Metal Box	ULCF30002GRM	ULDF60002RM	ULFX60002RM
P44	2 Loop Panel, Integral Printer, Network Card	ULCF30002GPNC	ULDF60002GPNC	ULFX60002GPNC
P44	2 Loop Panel, Integral Printer, Red Metal Box	ULCF30002GPRM	ULDF60002PRM	ULFX60002PRM
P44	2 Loop Panel, Network Card, Red Metal Box	ULCF30002GNCRM	ULDF60002NCRM	ULFX60002NCRM
P44	2 Loop Panel, Integral Printer, Network Card, Red Metal Box	ULCF30002GPNCRM	ULDF60002PNCRM	ULFX60002PNCRM
P44	4 Loop Panel	ULCF30004G	ULDF60004G	ULFX60004G
P44	4 Loop Panel, Integral Printer	ULCF30004GP	ULDF60004GP	ULFX60004GP
P44	4 Loop Panel, Network Card	ULCF30004GNC	ULDF60004GNC	ULFX60004GNC
P44	4 Loop Panel, Red Metal Box	ULCF30004GRM	ULDF60004RM	ULFX60004RM
P44	4 Loop Panel, Integral Printer, Network Card	ULCF30004GPNC	ULDF60004GPNC	ULFX60004GPNC
P44	4 Loop Panel, Integral Printer, Red Metal Box	ULCF30004GPRM	ULDF60004PRM	ULFX60004PRM
P44	4 Loop Panel, Network Card, Red Metal Box	ULCF30004GNCRM	ULDF60004NCRM	ULFX60004NCRM
P44	4 Loop Panel, Integral Printer, Network Card, Red Metal Box	ULCF30004GPNCRM	ULDF60004PNCRM	ULFX60004PNCRM
P45	Rack Mounted 2 Loop Panel	ULR3000L2	ULR3000L2	ULR3000L2
P45	Rack Mounted 2 Loop Panel c/w Network Card	ULR3000L2NC	ULR3000L2NC	ULR3000L2NC
P45	Rack Mounted 4 Loop Panel	ULR3000L4	ULR3000L4	ULR3000L4
P45	Rack Mounted 4 Loop Panel c/w Network Card	ULR3000L4NC	ULR3000L4NC	ULR3000L4NC
P45	Loop repeater panel	ULCF3000PRG	ULDF6000PRG	ULFX6000PRG
P45	Network touchscreen repeater panel	ULCTPR3000	ULDPTR6000	ULFPTR6000
P46	Addressable Sensor Base	UCAB300	UCAB300	UCAB300
P46	ULCAP320 Optical Smoke Sensor	400005FIRE-0011X	400005FIRE-0011X	400005FIRE-0011X
P46	ULCAPT340 Photo-Thermal Sensor	400006FIRE-0012X	400006FIRE-0012X	400006FIRE-0012X
P46	ULCAH330 Heat Sensor	400007FIRE-0013X	400007FIRE-0013X	400007FIRE-0013X
P48	2 Wire Detector, Optical	UCPD-2W	UCPD-2W	UCPD-2W
P48	2 Wire Detector, Opto-Heat	UCPT-2W	UCPT-2W	UCPT-2W
P48	2 Wire Detector, Fixed Heat 135°F	UCHT-2W	UCHT-2W	UCHT-2W
P48	2 Wire Detector, Fixed Heat 194°F	UCHTI-2W	UCHTI-2W	UCHTI-2W
P48	2 Wire Detector, Rate of Rise and Fixed Heat 135°F	UCHR-2W	UCHR-2W	UCHR-2W
P48	2 Wire Detector, Rate of Rise and Fixed Heat 194°F	UCHRI-2W	UCHRI-2W	UCHRI-2W
P49	Standard Detector Base	CB2E	CB2E	CB2E
P50	Wall Mount Horn	CN126292	CN126292	CN126292
P50	Ceiling Mount Horn	CN128972	CN128972	CN128972
P50	Wall Mount Horn Strobe	CN127249	CN127249	CN127249
P50	Wall Mount Synchronised Strobe	CN127380	CN127380	CN127380
P50	Ceiling Mount Horn Strobe	CN127464	CN127464	CN127464
P50	Ceiling Mounted Synchronised Strobe	CN127488	CN127488	CN127488
P51	Wall Mount Outdoor Synchronised Strobe	CN129013	CN129013	CN129013
P51	Ceiling Mount Outdoor Synchronised Strobe	CN124338	CN124338	CN124338
P51	Exposed Conduit, Surface Mount Back Box (RED)	CN109751	CN109751	CN109751

Product code cross reference

Page No.	Description	Cooper Code	Menvier Code	JSB Code
P51	Concealed Conduit Surface Mount Back Box (RED)	CN109751 + CN104486	CN109751 + CN104486	CN109751 + CN104486
P52	Single Action Pull Station	UMPS-100	UMPS-100	UMPS-100
P52	Weatherproof Single Action Pull Station	UMPS-100WP	UMPS-100WP	UMPS-100WP
P52	Double Action Pull Station	UMPS-200	UMPS-200	UMPS-200
P52	Weatherproof Double Action Pull Station	UMPS-200WP	UMPS-200WP	UMPS-200WP
P52	Conventional Single Action Pull Station (back box ordered seperately)	SG42BK2	SG42BK2	SG42BK2
P52	Conventional Double Action Pull Station (back box ordered seperately)	SG42BK1	SG42BK1	SG42BK1
P52	Back box for conventional, surface mounting	SGB32S	SGB32S	SGB32S
P52	Back box for conventional, weatherproof	SGB-32C	SGB-32C	SGB-32C
P54	4 Way Sounder Controller Unit	ULCSC354	ULCSC354	ULCSC354
P54	Shop Monitor Unit	ULCSUM355	ULCSUM355	ULCSUM355
P54	Spur Isolator Unit	ULCSI350	ULCSI350	ULCSI350
P54	3 Channel Input/Output Unit Resets on reset	ULCIO351	ULCIO351	ULCIO351
P54	3 Channel Input/Output Unit Resets on silence alarms	ULCIO351S	ULCIO351S	ULCIO351S
P54	120V/230V ac Relay Unit	ULCMIO353	ULCMIO353	ULCMIO353
P55	Micro Zone Monitor Unit	ULMIU872	ULMIU872	ULMIU872
P55	ULMCOM Micro Single Channel Output Unit (recognised as output unit)	400015FIRE-0029X	400015FIRE-0029X	400015FIRE-0029X
P55	ULMCOM-S Micro Single Channel Output Unit (recognised as sounder)	400016FIRE-0030X	400016FIRE-0030X	400016FIRE-0030X
P55	ULMCIM Micro Single Channel Input Unit (recognised as input unit)	400013FIRE-0027X	400013FIRE-0027X	400013FIRE-0027X
P55	ULMCIM-C Micro Single Channel Input Unit (recognised as callpoint)	400014FIRE-0028X	400014FIRE-0028X	400014FIRE-0028X
P55	Mini Module Box Unit (Empty box)	ULBU	ULBU	ULBU
Conventional				
P58	2 zone BiWire Ultra panel	EFBW2ZONE	EFBW2ZONE	EFBW2ZONE
P58	4 zone BiWire Ultra panel	EFBW4ZONE	EFBW4ZONE	EFBW4ZONE
P58	8 zone BiWire Ultra panel	EFBW8ZONE	EFBW8ZONE	EFBW8ZONE
P60	BiWire Ultra wall sounder	EF009	EF009	EF009
P60	BiWire Ultra wall sounder, weatherproof	EF009WP	EF009WP	EF009WP
P60	BiWire Ultra wall sounder VAD	EF009SB	EF009SB	EF009SB
P60	BiWire Ultra wall sounder VAD, weatherproof	EF009SBWP	EF009SBWP	EF009SBWP
P60	BiWire Ultra base sounder first fix	EF5021BWS	EF5021BWS	EF5021BWS
P60	BiWire Ultra base sounder VAD first fix	EF5021BWSB	EF5021BWSB	EF5021BWSB
P60	BiWire Ultra Slim Base sounder with cover	EF5023S	EF5023S	EF5023S
P60	BiWire Ultra Slim Base sounder VAD with cover	EF5023SB	EF5023SB	EF5023SB
P61	BiWire Ultra detector 5 in 1	EFBW5IN1DET	EFBW5IN1DET	EFBW5IN1DET
P61	BiWire Ultra callpoint	EF201BWCP	EF201BWCP	EF201BWCP
P61	BiWire callpoint, weatherproof	EF203BWCWP	EF203BWCWP	EF203BWCWP

Product code cross reference

Page No.	Description	Cooper Code	Menvier Code	JSB Code
P62	2 zone BiWire Flexi panel	EFBW2ZFLEXI	EFBW2ZFLEXI	EFBW2ZFLEXI
P62	4 zone BiWire Flexi panel	EFBW4ZFLEXI	EFBW4ZFLEXI	EFBW4ZFLEXI
P62	8 zone BiWire Flexi panel	EFBW8ZFLEXI	EFBW8ZFLEXI	EFBW8ZFLEXI
P62	2 zone relays + FRE/FPE	BWOB2Z	BWOB2Z	BWOB2Z
P62	4 zone relays + FRE/FPE	BWOB4Z	BWOB4Z	BWOB4Z
P62	8 zone relays + FRE/FPE	BWOB8Z	BWOB8Z	BWOB8Z
P62	BiWire End of line module	BWEOLM-3	BWEOLM-3	BWEOLM-3
P62	Conventional End of line module	EOLM-1	EOLM-1	EOLM-1
P62	12V, 5Ah battery (1pc*) *2 required	MB512	MB512	MB512
P64	8 Zone Conventional Panel	EFCV8Z	EFCV8Z	EFCV8Z
P64	End of Line Module	EOLM-1	EOLM-1	EOLM-1
P64	8 Zone Relays + FRE/FPE	BWOB8Z	BWOB8Z	BWOB8Z
P67	Conventional 2 Zone Panel	FX2202CPD	FX2202CPD	FX2202CPD
P67	Conventional 4 Zone Panel	FX2204CPD	FX2204CPD	FX2204CPD
P67	Steel back box (for use with FX2202/4/8)	FX22003300 MB	FX22003300 MB	FX22003300 MB
P67	Repeater Panel	FXRP2200	FXRP2200	FXRP2200
P67	Fire Alarm System Log Book	MFALOG	MFALOG	MFALOG
P68	16 Zone Control Panel	CF50016	MF50016	FXP50016
P69	Repeater Panel	CF5000RP	MF5000RP	FXP5000RP
P69	Fire Alarm System Log Book	MFALOG	MFALOG	MFALOG
P70	5 in 1 Multi-Mode Detector	FXN922	FXN922	FXN922
P70	Optical Smoke detector	CPD321	MPD821	FXN533
P70	Photo-Thermal detector	CPT341	MPT951	FXN632
P70	Rate of rise heat detector	CFR330	MFR830	FXN525
P70	Fixed Heat detector 77°C	CMT360	MMT860	FXN524
P70	Fixed Heat detector 92°C	CMT390	MHT890	FXN526
P70	Remote Indicator	CIR301	FX251D	FX251D
P70	Weatherproof Remote Indicator	CIR301WP	CIR301WP	CIR301WP
P72	Standard Base	CDBB300	MDB800	FXN520
P72	Relay Base	FXN520R	MDB800R	FXN520R
P72	Reflective Beam Detector (50m range)	MBD50R	MBD50R	MBD50R
P72	Reflective Beam Detector (100m range)	MBD100R	MBD100R	MBD100R
P72	Mounting Bracket	MRBFP	MRBFP	MRBFP
P73	Duct Probe	MDP201	MDP201	MDP201
P75	Surface/Flush Callpoint	CX201	MBG914	FX201
P74	Weatherproof Callpoint	CX203	MBG917	FX203
P74	CXPC Protective Hinged Cover (pack of 10)	4990001FUL-0022	4990001FUL-0022	4990001FUL-0022
P74	Spacer Plates (pack of 10)	MBGSP	MBGSP	MBGSP
P74	MBGBEZ Recessing Bezels (pack of 10)	4990005FUL-0194	4990005FUL-0194	4990005FUL-0194
P74	MBGREKIT Resettable Element Kit (pack of 10)	4990010FUL-0045	4990010FUL-0045	4990010FUL-0045

Product code cross reference

Page No.	Description	Cooper Code	Menvier Code	JSB Code
P74	FX5G Spare Break Glasses (pack of 10)	516200FULL-5017	516200FULL-5017	516200FULL-5017
P74	Earth Continuity Links (pack of 5)	MBG119	MBG119	MBG119
P74	MFBGKEY3 Callpoint Keys (pack of 10)	4990009FUL-0040	4990009FUL-0040	4990009FUL-0040
P77	FX006 Internal 6 Inch Bell	521601FULL-1601	521601FULL-1601	521601FULL-1601
P77	FX003 Flush Sounder, Red	550001FULL-0001X	550001FULL-0001X	550001FULL-0001X
P77	FX003W Flush Sounder, White	550015FULL-0017X	550015FULL-0017X	550015FULL-0017X
P77	MFSSBB Back Box For FX003, Red	591001FULL-0016	591001FULL-0016	591001FULL-0016
P77	FX002SB Low Profile Surface Sounder, Red	540501FULL-0389X	540501FULL-0389X	540501FULL-0389X
P77	FX002DB Weatherproof Surface Sounder, Red	540503FULL-0403X	540503FULL-0403X	540503FULL-0403X
P77	FX007 High Output Wall Sounder	651004FULL-0009X	651004FULL-0009X	651004FULL-0009X
P77	MLC624 Low Current Wall Sounder	650001FULL-0003X	650001FULL-0003X	650001FULL-0003X
P77	FXN824 Base Mountable Sounder	666058FULL-0098X	666058FULL-0098X	666058FULL-0098X
P77	MDS824COV Blanking Plate for MDS824 (pack of 5)	590037FULL-0305	590037FULL-0305	590037FULL-0305
P79	FXSOLWRS Solista Wall Red Body Shallow Base	812013FULL-0237X	812013FULL-0237X	812013FULL-0237X
P79	FXSOLWRD Solista Wall Red Body Deep Base	812005FULL-0107X	812005FULL-0107X	812005FULL-0107X
P79	FXSOLCWS Solista LX Ceiling	812022FULL-0123X	812022FULL-0123X	812022FULL-0123X
P79	FXROLPWR RoLP Wall Red Body Base & Sounder	8500025FULL-0025X	8500025FULL-0025X	8500025FULL-0025X
P79	FXROLPWR-B RoLP Wall Red Body Base	8500040FULL-0219X	8500040FULL-0219X	8500040FULL-0219X
P79	FXSYG1WR Symphoni LX Wall Red Body	8500045FULL-0233X	8500045FULL-0233X	8500045FULL-0233X
P79	FXSYR-B Symphoni LX Wall Base Red Body	8500095FULL-0231X	8500095FULL-0231X	8500095FULL-0231X
P79	FXSYG1WR-WP Symphoni LX Wall Weatherproof Red Body	8500050FULL-0249X	8500050FULL-0249X	8500050FULL-0249X
P79	FXSYR-B-WP Symphoni LX Wall Weatherproof Base Red Body	8500100FULL-0247X	8500100FULL-0247X	8500100FULL-0247X
P79	Deep base for Solista LX Ceiling	FX000WWP	FX000WWP	FX000WWP
P80	MLB124SB Low Profile LED indicator	811012FULL-0006	811012FULL-0006	811012FULL-0006
P80	MLB124DB Weatherproof LED Beacon	811013FULL-0007	811013FULL-0007	811013FULL-0007
P80	FL-RLR-S Conventional xenon sounder indicator	640001FULL-0003X	640001FULL-0003X	640001FULL-0003X
P80	FL-RLR-D Weatherproof IP65 xenon sounder indicator	640031FULL-0111X	640031FULL-0111X	640031FULL-0111X
P82	Mains Powered Heavy Duty Door Retainer	MDR240	MDR240	MDR240
P82	24V dc Heavy Duty Door Retainer	MDR24L	MDR24L	MDR24L
P82	Floor Mounting Bracket for Heavy Duty Door Retainers	ZMDRFBB	ZMDRFBB	ZMDRFBB
P82	24V dc Compact Door Retainer	FX02124VLC	FX02124VLC	FX02124VLC
P82	Mains Powered Compact Door Retainer	FX021240LC	FX021240LC	FX021240LC
P82	Floor Mounting Bracket for Compact Door Retainers	FX021LCFB	FX021LCFB	FX021LCFB
P82	Spare Striker Plate For Either Magnet	ZMDRSWIV	ZMDRSWIV	ZMDRSWIV
P82	Heavy Duty Relay Unit	MAR724	MAR724	MAR724
P83	Safety Power Supply 24V / 1.5A (batteries not supplied)	SPS-2423	SPS-2423	SPS-2423
P83	Safety Power Supply 24V / 2.5A (batteries not supplied)	SPS-2433	SPS-2433	SPS-2433
P83	Safety Power Supply 24V / 4.5A (batteries not supplied)	SPS-2453	SPS-2453	SPS-2453
Emergency Voice Communications and Emergency Assist Alarms				
P86	VoCALL 10 Line Networkable Master System Handset	CFVCWM	CFVCWM	CFVCWM

Product code cross reference

Page No.	Description	Cooper Code	Menvier Code	JSB Code
P86	VoCALL 8 Line Network Exchange Unit	CFVCX8	CFVCX8	CFVCX8
P87	VoCALL Compact 9 Line Master Unit	CFVCCM9	CFVCCM9	CFVCCM9
P87	VoCALL 10 Line Slave Exchange Unit	CFVCCS10	CFVCCS10	CFVCCS10
P88	VoCall Compact 5 Line Master Exchange Unit, Non-Network, Surface Mount, Graphite	ESVCC5	ESVCC5	ESVCC5
P88	VoCall Compact 5 Line Master Exchange Unit, Non-Network, Flush Mount, Graphite	EFVCC5	EFVCC5	EFVCC5
P88	VoCall Compact 5 Line Master Exchange Unit, Non-Network, Surface Mount, Stainless Steel	ESVCC5SS	ESVCC5SS	ESVCC5SS
P88	VoCall Compact 5 Line Master Exchange Unit, Non-Network, Flush Mount, Stainless Steel	EFVCC5SS	EFVCC5SS	EFVCC5SS
P80	VoCall Type A Outstation, Surface Mount, Red	CFVCSHP	CFVCSHP	CFVCSHP
P90	VoCall Type A Outstation, Surface Mount, Stainless Steel	CFVCSHPSS	CFVCSHPSS	CFVCSHPSS
P90	VoCall Type A Outstation, Flush Mount, Red	CFVCFHP	CFVCFHP	CFVCFHP
P90	VoCall Type A Outstation, Flush Mount, Stainless Steel	CFVCFHPSS	CFVCFHPSS	CFVCFHPSS
P90	VoCall Type A uncased red handset	CFVCHFS	CFVCHFS	CFVCHFS
P90	VoCall Type A Outstation, IP65 Lockable, Surface Mount, Red	CFVCIPA	CFVCIPA	CFVCIPA
P90	VoCall Type B Outstation, Surface Mount, Red	CFVCSHF	CFVCSHF	CFVCSHF
P90	VoCall Type B Outstation, Surface Mount, Green	CFVCSHFG	CFVCSHFG	CFVCSHFG
P90	VoCall Type B Outstation, Surface Mount, Stainless Steel	CFVCSHFSS	CFVCSHFSS	CFVCSHFSS
P90	VoCall Flush Mounting Bezel for use with any Type B Outstation, Stainless Steel	CFVCFHB	CFVCFHB	CFVCFHB
P90	VoCall Combined Type A and Type B flush mount outstation	CFVCDUO	CFVCDUO	CFVCDUO
P90	VoCall Jack Plate	CFVCRJP	CFVCRJP	CFVCRJP
P90	VoCall Roaming Handset	CFVCRHS	CFVCRHS	CFVCRHS
P93	Emergency assist alarm - vocall kit	CFVCEA	CFVCEA	CFVCEA
P93	Emergency assist alarm - stand alone kit	CFEAPULLKIT	CFEAPULLKIT	CFEAPULLKIT
P93	4 way splitter	CFEASL4	CFEASL4	CFEASL4
P93	Pull cord unit	CFEAPULL	CFEAPULL	CFEAPULL
P93	Disabled sticker (pack of 5)	CFEADS	CFEADS	CFEADS
Voice				
P96	2 x 50W Addressable DAU	EESDAU100	EESDAU100	EESDAU100
P96	Emergency Microphone All Call	EESEMA	EESEMA	EESEMA
P98	Vandal Resistant Speaker	SENTRY6ST/ENC	SENTRY6ST/ENC	SENTRY6ST/ENC
P98	Sound Projector Speaker	CAD10T/ENC	CAD10T/ENC	CAD10T/ENC
P98	Weatherproof Horn	APH10T/ENC	APH10T/ENC	APH10T/ENC
P98	Ceiling Loudspeaker 5 Watt	MC5-EN	MC5-EN	MC5-EN
P98	Ceiling Loudspeaker 6 Watt	MC6-EN	MC6-EN	MC6-EN





Contact

Eaton

Cooper Lighting and Safety Ltd
Wheatley Hall Road
Doncaster
South Yorkshire
DN2 4NB
United Kingdom
www.cooperfire.com
www.uk.eaton.com

Sales

T: +44 (0)1302 303 999
F: +44 (0)1302 303 333
E: FireSales@eaton.com

Technical and Quotations

T: +44 (0)1302 303 350
F: +44 (0)1302 303 332
E: techsupport@cooperfire.com

Service

T: +44 (0)1302 303 352
F: +44 (0)1302 303 332
E: service@cooperfire.com

Export

T: +44 (0)1302 303 344
F: +44 (0)1302 303 345
E: export@cooperfire.com

Online Resources

Visit www.cooperfire.com for the following resources:

- 24/7 online product support
- Catalogue and literature
- Product profiles
- Datasheets, installation and user manuals

At Eaton, we're energized by the challenge of powering a world that demands more. With over 100 years experience in electrical power management, we have the expertise to see beyond today. From groundbreaking products to turnkey design and engineering services, critical industries around the globe count on Eaton.

We power businesses with reliable, efficient and safe electrical power management solutions. Combined with our personal service, support and bold thinking, we are answering tomorrow's needs today.

Follow the charge with Eaton, visit eaton.eu

Eaton
Electrical Sector EMEA
Route de la Longeraie 7
1110 Morges, Switzerland

Eaton
Eaton Electrical Systems Ltd.
Wheatley Hall Road
Doncaster
South Yorkshire
DN2 4NB
United Kingdom
Tel: +44 (0)1302 303 999
Fax: +44 (0)1302 303 333
Email: FireSales@eaton.com
Web: www.cooperfire.com
www.uk.eaton.com

© 2017 Eaton
All Rights Reserved
Pub Reference: CF-CC2556
February 2017